



# WM2110

## Series Q<sup>2</sup>™ Low Level Waste Assay Systems



Figure 1: The Model WM2110 Germanium Q<sup>2</sup> Low Level Waste Assay System.

### KEY FEATURES

- Provides qualitative and quantitative gamma assays for waste in 208 L (55 gal) drums
- Sensitivity better than 370 Bq (10 nCi) for 208 liter (55 gal) drums
- Factory calibrated for turnkey operation, and includes QA check source and holder
- Low background 10 cm (4 in.) steel shield
- Automatic weighing system for matrix attenuation corrections due to sample density
- PC-based control and analysis system featuring the user-friendly Mirion NDA-2000™ Waste Assay Software package
- Standardized modular design for easy customization:
  - Shield pre-drilled for field installation of all available options
  - Optional upgrade to 15 cm (6 in.) steel shield
  - Optional manual or automatic LN<sub>2</sub> fill systems for Ge detectors
  - Optional electrically-assisted drum loader
  - Optional environmentally-controlled equipment cabinet with heating and air conditioning units

### DESCRIPTION

Most nuclear facilities treat all materials as radioactive waste, simply because they have been in an area where they might have become contaminated. Likewise, expensive components are sometimes discarded as contaminated because they have inaccessible surfaces which cannot be tested for contamination. These are very expensive practices which can be avoided through judicious use of a sensitive Q<sup>2</sup> (Qualitative and Quantitative) Low Level Waste Assay system to insure the most cost-effective handling of your waste. By optimizing waste disposal with a WM2110 Series Q<sup>2</sup> assay system, a typical nuclear power plant can expect a payback period of less than one year through reduced radioactive waste disposal costs.

Alternative systems based upon gross counting methods do not allow specific release limits for individual isotopes, plus they allow the natural radioactivity of radium, thorium, <sup>40</sup>K, or background fluctuations to contribute to measured levels. The result is overstated activity levels and unnecessary added disposal costs, which quickly offset any initial costs savings that may have been realized when the system was purchased.

The high resolution and wide dynamic range of its germanium detectors make the Model WM2110 system the choice for waste material containing totally unknown and/or complex mixtures, particularly when the samples contain both low energy and high energy nuclides.

#### SHIELD AND COUNTING CHAMBER

The WM2110 shield design in its standard configuration totally encloses the sample in 10 cm (4 in.) of low background steel. Optionally it may be upgraded to 15 cm (6 in.) thick steel at the time of purchase. To further simplify field upgrades, the shield is pre-drilled for all options, with steel plugs provided for any unused openings.

To facilitate decontamination in the event of a sample spill, the inside of the counting chamber is covered by a thin stainless steel liner. For counting applications of low energy gamma rays, a low-density liner is available as an option.

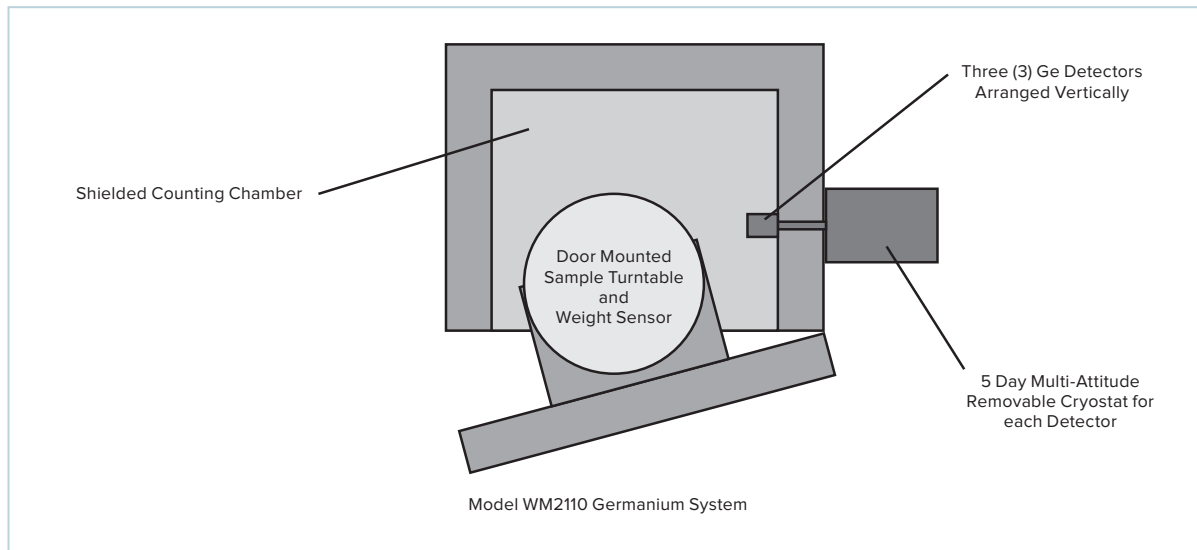

Figure 2: Schematic Diagram of the WM2110 System as Seen From Above.

## SAMPLE TURNTABLE AND WEIGHING SYSTEM

The drum or other sample container is placed on a turntable, which is mounted to the door to facilitate the loading and unloading process. When the counting chamber door is closed, the turntable rotates at approximately 10 rpm. Strain gauges mounted in the turntable structure automatically weigh the sample. This data is fed to the system computer which uses it to correct analysis results for matrix attenuation due to sample density.

## DETECTORS

As shown in Figure 2, the WM2110 system uses three uncollimated germanium detectors mounted vertically along the right side of the counting chamber. The detectors are mounted in five-day multi-attitude cryostats, with manual or optional automatic LN<sub>2</sub> fill systems available.

## NUCLEAR ELECTRONICS

The nuclear signal processing and data acquisition functions are handled via the Mirion computer-controlled Digital Signal Processors (DSP). They connect to the Host PC via an Ethernet link, giving the application software the ability to manage all signal processing remotely from the Host.

## SYSTEM PC

A Pentium class PC serves as the Host for the system. It includes an Ethernet link to the DSP electronics, which can also be used to tie the system into a laboratory-wide network, an RS-232C communications link to the Sample Weighing System, and all needed local storage and reporting devices.

## SYSTEM SOFTWARE

### GENIE™ 2000 SOFTWARE FOR ACQUISITION AND DISPLAY

The powerful Genie 2000 package serves as the base for the application software, providing it with a friendly but flexible data acquisition and display facility. In addition, Genie 2000 software provides all of the needed editors and utilities for those behind-the-scenes operations like Calibration and Quality Assurance which are essential to any turnkey installation.

### BASIC WASTE ASSAY SOFTWARE

The user-friendly NDA-2000 Waste Assay Software package is the operator's interface. To initiate an assay, all the operator must do is select the count type to be performed, then fill in the blanks on the Sample ID screens which are displayed. The assay process and report generation are then automatically performed.

Once the assay is complete, the results are automatically stored. A wide range of data retrieval and report generation functions are included for reporting results in any special site-specific format.

### PERFORMANCE

A minimum detectable activity of 111 Bq (3 nCi) at 0.1 g/cc material to 446 Bq (12 nCi) at 1.7 g/cc material per drum can be achieved for nuclides with gamma energies from 300 to 1500 keV and 100% gamma abundance. This sensitivity can be achieved in 10 minutes for the germanium system (one minute with NaI detectors). Worst case accuracy will typically be less than plus or minus a factor of three for point sources of radioactivity located anywhere in the sample chamber when the sample density is 1 g/cc or less.

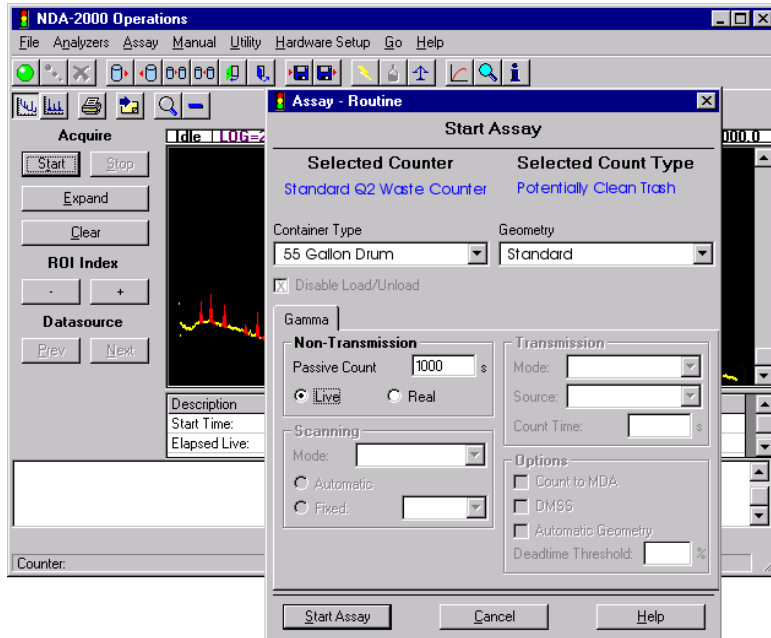

Figure 3: Example of NDA-2000 Screen.

For a more detailed look at the performance of the Model WM2110 germanium system for a variety of nuclides, refer to Table 1.

### TURNKEY SYSTEM PHILOSOPHY

Each system is completely assembled, integrated, tested and individually calibrated at the factory. Documentation of this calibration, and generic accuracy data is provided. Each system is delivered with a QA check source and counting fixture to confirm the validity of the factory calibration. (Calibration drums and sources are available as options.)

Table 1: Model WM2110 Germanium Q<sup>2</sup> Lower Limit of Detection – Typical and Worst Case.

Nuclide	Daughter Measured	Energy (keV)	Typical LLD in pCi/g [Bq/g] Density (g/cc)				Worst Case LLD in pCi/g [Bq/g] Density (g/cc)			
			0.1	0.3	0.8	1.8	0.1	0.3	0.8	1.8
Cs-137	Ba-137	662	0.18 [0.01]	0.08 [0.003]	0.05 [0.002]	0.04 [0.001]	0.26 [0.01]	0.13 [0.005]	0.15 [0.01]	0.44 [0.02]
Cs-134		800	0.15 [0.01]	0.07 [0.003]	0.04 [0.001]	0.03 [0.001]	0.21 [0.01]	0.11 [0.004]	0.11 [0.004]	0.27 [0.01]
Co-60		1173	0.15 [0.01]	0.06 [0.002]	0.04 [0.001]	0.03 [0.001]	0.20 [0.01]	0.09 [0.003]	0.09 [0.003]	0.16 [0.01]
Co-58		810	0.15 [0.01]	0.07 [0.003]	0.04 [0.001]	0.03 [0.001]	0.21 [0.01]	0.11 [0.004]	0.11 [0.004]	0.27 [0.01]
Ce-144	Pr-144	134	2.00 [0.07]	0.94 [0.03]	0.68 [0.03]	0.66 [0.02]	2.90 [0.11]	1.70 [0.06]	4.50 [0.17]	33.00 [1.22]
Th-232		908	0.55 [0.02]	0.24 [0.01]	0.15 [0.01]	0.12 [0.004]	0.73 [0.03]	0.39 [0.01]	0.38 [0.01]	0.80 [0.03]
Th-228	Pb-212	239	0.35 [0.01]	0.16 [0.01]	0.12 [0.004]	0.10 [0.004]	0.50 [0.02]	0.29 [0.01]	0.60 [0.02]	3.40 [0.13]
Th-228	Tl-208	583	0.47 [0.02]	0.20 [0.01]	0.14 [0.01]	0.12 [0.004]	0.64 [0.02]	0.33 [0.01]	0.42 [0.02]	1.70 [0.06]
Th-228	Tl-208	2614	0.22 [0.01]	0.09 [0.003]	0.04 [0.001]	0.03 [0.001]	0.29 [0.01]	0.14 [0.01]	0.09 [0.003]	0.10 [0.004]
U-238	Th-234	93	6.20 [0.23]	3.00 [0.11]	2.30 [0.09]	2.40 [0.09]	9.10 [0.34]	5.70 [0.21]	19.20 [0.71]	150.00 [5.55]
U-238	Pa-234m	1001	26.70 [0.99]	11.10 [0.41]	6.90 [0.26]	5.80 [0.21]	36.00 [1.33]	17.00 [0.63]	17.30 [0.64]	38.70 [1.43]
U-238	Bi-214	609	0.32 [0.01]	0.14 [0.01]	0.09 [0.003]	0.07 [0.003]	0.47 [0.02]	0.23 [0.01]	0.27 [0.01]	0.79 [0.03]
U-235		185	0.32 [0.01]	0.15 [0.01]	0.11 [0.004]	0.10 [0.004]	0.46 [0.02]	0.27 [0.01]	0.64 [0.02]	4.30 [0.16]
Pu-239 (nCi/g)		414	11.70 [433]	5.30 [196]	3.80 [141]	3.10 [115]	16.70 [618]	9.10 [337]	14.00 [518]	69.10 [2557]

CONDITIONS – Uniform source calibration at appropriate density; three Ge detectors; 10 minute sample count time; full sample container at stated density.

LLD (Lower Limit of Detection) – 5% Type I error, 5% Type II error.

WORST CASE LLD – Maximum activity present if all activity is in a 1 cm diameter sphere which is at the worst location in a homogeneous density sample.

## SPECIFICATIONS

### SAMPLE CAPACITIES

- SIZE – 208 L (55 gal) drums. (64 x 89 cm (25 x 35 in.) diameter x height, max.).
- WEIGHT – 454 kg (1000 lb) max.

### SHIELD

- MATERIAL –
  - Standard: 10 cm (4 in.) thick low background steel.
  - Optional: 15 cm (6 in.) thick low background steel.
- Turntable for drum rotation.

### AUTOMATIC SAMPLE WEIGHT SYSTEM

- TYPE – Load cell.
- CAPACITY – 0 to 454 kg (0 to 1000 lb).
- Includes controller and RS-232C communications to the Host PC.

### DETECTORS

- Three each Coaxial Germanium detectors mounted in five-day multi-attitude cryostats with manual LN<sub>2</sub> fill system.

### SIGNAL PROCESSING ELECTRONICS

- Advanced computer-controlled DSP electronics.
- Includes Ethernet link to the Host PC.

### PC SOFTWARE

- Genie 2000 spectroscopy package.
- Basic waste assay package.
- Ethernet link to the DSP electronics.
- RS-232C link to the automatic sample weight system.

### PERFORMANCE

Overall performance varies with the details of the system configuration, ambient background radiation, sample matrix, and counting time. Refer to Table 1 for typical performance levels that can be expected for various nuclides.

### PHYSICAL

- SIZE – 152 x 173 x 122 cm (60 x 68 x 48 in.) H x W x D.
- WEIGHT –
  - 10 cm shield: 7260 kg (16 000 lb).
  - 15 cm shield: 9980 kg (22 000 lb).

### ENVIRONMENTAL

- TEMPERATURE – 0 to 40 °C.
- HUMIDITY – 0-95%, non-condensing.
- Meets the environmental conditions specified by EN 61010, Installation Category I, Pollution Degree 2.

### POWER

- 110/220 V ac, 3 kVA.

### OPTIONS

The following options are available for configuring the WM2110 system to meet site-specific needs. They all may be added in the field.

- 15 cm shielding option: adds an additional 5 cm (2 in.) of low background shielding to the basic 10 cm (4 in.) shield.
- ISOCS™ detector calibration and software.
- BEGe™ detector (maximum endcap size must be determined).
- Cryo-Pulse® 5 cryostat for LN<sub>2</sub>-free solution.
- Lynx® Digital Spectrum Analyzer.
- Factory Acceptance Test, Site Acceptance Test, Training.
- Electrically assisted drum loader.
- Environmentally-controlled equipment cabinet.
- Calibration drums and sources.
- Automatic LN<sub>2</sub> fill system.



©2017 Mirion Technologies (Canberra), Inc. All rights reserved.

Copyright ©2017 Mirion Technologies, Inc. or its affiliates. All rights reserved. Mirion, the Mirion logo, and other trade names of Mirion products listed herein are registered trademarks or trademarks of Mirion Technologies, Inc. or its affiliates in the United States and other countries. Third party trademarks mentioned are the property of their respective owners.

# CANBERRA