



MIRION
TECHNOLOGIES

Edition 3.0



Health Physics and Radiation Safety Instruments

Precise Protection for
Confident Operations





MIRION
TECHNOLOGIES

Protect What's Next.™

Advancing Radiation Safety.

At Mirion Technologies, we partner with industry leaders to advance radiation safety and empower the next wave of critical innovation. From detection and measurement to monitoring and analysis, we empower innovators across industries with radiation safety technologies that operate with the highest levels of precision. We partner with our customers to build solutions that deliver complete confidence in safe operations and harness the transformative power of safe radiation to move our world forward.



Precise Protection for Confident Operations

For the field of Health Physics, we specialize in the design, development and production of equipment, solutions and services to provide personnel protection in any site or facility utilizing radioactive materials.

FEATURED PRODUCTS

Page 8



DMC 3000™
Personal Electronic
Dosimeter

Page 22



ORION™
Real-Time
Location System

Page 26



RDS-32™
Survey Meter

Page 27



AccuRad™
PRD Personal
Radiation
Detector

Page 44



Argos™ -3/-5
Whole Body
Contamination
Monitors

Page 73



iCAM™ Mobile
Alpha Beta
Particulate
Monitor

TABLE OF CONTENTS

1. Electronic Dosimetry.....6

Dosimeters

DMC 3000™ Personal Electronic Dosimeter.....	8
DMC 3000 & Bluetooth® Module Connectivity Module for DMC 3000 Dosimeter.....	9
ConnectStudio™ Connectivity Management Software.....	9
MirionWatch™ Device for DMC 3000™ Bluetooth® Module.....	10
DMCUser™ Electronic Dosimeters Management and Maintenance Software.....	10
Telemetry Module (Tx).....	11
Location Telemetry Module (LTx).....	11
Enhanced Telemetry Module (eTx).....	11
Neutron Telemetry Module (NTx).....	11
Neutron Module Hp10.....	11
Beta Module.....	11

Dosimeter Accessories

LDM 320W™ and LDM 320D™ Hands-Free Dosimeter Reader.....	12
IRD 2000/3000 Irradiator for Electronic Dosimeter Calibrations and Response Checking.....	13
Passive Entry Turnstile.....	14
RWP Turnstile Smart Safety Checkpoint.....	14
LDM 3200™ RCA Entry/Exit Reader.....	15
LDM 1000™ RCA Entry/Exit Reader.....	15

2. Telemetry.....16

AWM™ Adaptive Wireless Monitor.....	18
Active Dive Antenna for Teledosimetry Data Transmission.....	18
EcoGamma™-g Environmental Gamma Radiation Monitor.....	19
AMP-50™ Low Range GM Tube-Based Ratemeter and Area Monitor.....	20
AMP-100™ High Range GM Tube-Based Ratemeter and Area Monitor.....	20
AMP-200™ Very High Range GM Tube-Based Ratemeter and Area Monitor.....	20
AMP-300™ Very High Range Waterproof Gamma Detector.....	20
RDS-32™ AM Area Radiation Monitor.....	21
RPD-AM™ Radiological Posting Display Area Monitor.....	21

Orion™ Real-Time Location System

Orion Studio Software.....	20
Orion Anchor.....	20
Orion Asset Tag.....	21
Location Telemetry Module (LTx).....	21

3. Portable Radiation Measurement..... 22

Portable Survey Meters

RDS-32™ Modular Radiation Survey Meter.....	24
RDS-32 WR Wide Range Module Radiation Survey Meter.....	24
RDS-30™ Radiation Survey Meter.....	25
RDS-80™ Contamination Survey Meter.....	25
AccuRad™ PRD Personal Radiation Detector.....	25
AVIOR®-2 Desktop Dose-Rate and Survey Meter.....	26
Colibri® TTC & Colibri VLD Hand-Held Health Physics Communication ALARA* Platform.....	27

Contamination and Dose-rate Survey Probes

GMP-12SD™ External Gamma Probe.....	28
GMP-12UW™ External Gamma Probe.....	28
GMP-12GSD™ External Wide Range Gamma Probe.....	28
GMP-25™ External Alpha/Beta/Gamma Probe.....	29
RDS-32™ Telescope for External Probes.....	29
RDS-32™ Radiation Monitoring Alarm Box.....	29
Dose-Rate Probe Range.....	30
CSP™ Smart Contamination Probes.....	30
CSP Probes – Alpha Only.....	31
SA-32™ CSP Alpha Contamination Probe.....	31
SA-100™ Alpha Probe.....	31
SB-32™ Beta Probe.....	32
SB-100™ Beta Probe.....	32
SABG-15+™ Alpha/Beta/Gamma Probe.....	33
SPAB-15™ Alpha/Beta Probe.....	33
SAB-32™ Alpha/Beta Probe.....	34
SAB-250™ Alpha/Beta Probe.....	34
SAB-100™ Alpha/Beta Probe.....	35
SABG-100™ Alpha/Beta/Gamma Probe.....	35
SABP-525™ Foot Alpha/Beta Probe.....	36
EASY-COUNT™ Field Smear/Filter Counter.....	37
CSP Smart Contamination and Dose Equivalent Rate Probes.....	38
Contamination CSP Probes.....	38
SX-2R™ X-Ray Probe.....	38
SG-1R™ Gamma Probe.....	38
SG-2R™ Gamma Probe.....	39
SN-S™ Neutron Search Probe.....	39
Dose Equivalent Rate CSP Probes.....	40
STTC™ Wide Range Gamma Probe.....	40
SVLD™ Very Low Dose Rate Probe.....	40
SN-D-2™ Neutron Dose Probe.....	41
Tele-STTC-2™ Wide Range Gamma Telescopic Probe with RDS-32 meter.....	41

4. Contamination and Clearance	42	7. Airborne Radiation Monitoring	70
Personnel Monitors		ABPM 203M™ Mobile Alpha Beta Particulate Monitor.....	72
Argos™ Family Whole Body Surface Contamination Monitors	44	NGM 209M™ Mobile Low Range Noble Gas Monitor	72
Argos™-3 Compact Body Contamination Monitor	46	IM 201M™ Mobile Iodine Monitor	73
GEM™-5 Gamma Exit Monitor.....	47	iCAM™ Mobile Alpha Beta Particulate Monitor.....	73
HandFoot-Fibre™ XL Hand, Foot, Clothing Monitor (Gas-less)	48	8. Software	74
HandFoot-Fibre™ XL A+ Hand, Foot, Clothing with Alpha Monitor.....	48	SpirVIEW Mobile™ Situational awareness software	74
Sirius™-5 Hand, Cuff and Foot Surface Contamination Monitor.....	49	RPD™ Radiological Posting Display Software.....	75
Object Monitors		Horizon® Supervisory System Software.....	75
Cronos® Gamma Object/Tool Contamination Monitors	50	HIS-20™ Health Physics Information Record Keeping System.....	76
Cronos®-1PBG Beta/Gamma Object/Tool Monitor.....	50	DosiServ™ Dose Management Software.....	76
Cronos-1 Gamma Object/Tool Monitor.....	51	TeleView 3000™ Web Based Remote Monitoring System Software.....	77
Cronos-4 Gamma Object/Tool Monitor.....	51	DosiFFR™ First Responder's Dosimetry Management System Software	77
Cronos-11 Gamma Object/Tool Monitor.....	51	Software for Contamination Monitors	
Waste Monitors		CeMoSys™ 2.0 Central Monitoring System Software.....	78
CGO-Smart™ LNC Large Items Free Release Monitor	52	WebRemote® Contamination Monitor Interface	78
RTM661/440™ Large Object Monitor	52	Dashboard™ Web-based Monitor Overview Interface.....	78
RTM640Inc™ Waste Monitor.....	53	SOFT-LDB™ Local Database Support for Argos/GEM-5/Sirius/Cronos Contamination Monitors.....	79
RTM644Inc™ Large Waste Monitor.....	53	9. Geiger Mueller Detectors	80
RTM750™ Laundry and Small-Items Conveyor Monitor	54	Performance Data	82
Vehicle Monitors		Ordering Information	83
FastTrack-Vehicle™ Vehicle Monitor.....	55	10. Characterization Services	84
FastTrack-Vehicle™ XL Large Vehicle Monitor	55	Gamma Spectroscopy Services.....	85
Portal Monitors		High-Level Radioactivity Measurements.....	85
SPIR-Ident™ Portals Spectroscopic Radiation Portal Monitors (SRPM).....	56	On-site Services	85
SPIR-Ident™ Mobile Platform Airborne and Carborne Mobile Spectrometry.....	57	Challenging Characterization Situations	86
5. Training	58	Structures and Components.....	86
DMC 2000TD™ Electronic Dosimeter Training Device.....	60	Underwater Measurements.....	87
DMC 3000TD™ Electronic Dosimeter Training Device.....	60	Radiation Tolerant Cameras.....	87
SCC/Dongle Simulation Control Center and Wireless Communication Dongle.....	61	Nuclear Holdup Measurements	87
ICTD Model 9-4 Ion Chamber Training Device	61	Waste Characterization	87
TWR "Mini" Source Two Way Ranging "Live" Source of Radiation.....	62		
Rad Tag "Mini" TWR "Live" Source to DMC Training Device Interface.....	62		
GMP-25TD™ Contamination Probe Training Device.....	63		
6. Emergency Response and Preparedness	64		
Short Term Area Monitor Kit	66		
RDS-32 Response Kit Self-Contained Emergency Survey Kit.....	66		
DMC 3000 Response Kit Self-Contained Emergency Electronic Dosimetry Kit.....	67		
RBM™ Radiation Boundry Monitor.....	67		
SPIR-Ace™ Radionuclide Identification Device (RIID) with quantitative assessment capability.....	69		
SPIR-Explorer Sensor™ Light Weight Wide Range Radiological Detection and Identification Sensor	68		
SPIR-Pack™ man-portable detection and identification.....	69		
SpirVIEW Mobile™ Situational awareness software	69		



Electronic Dosimetry

The key component of an effective dose measurement program is the dosimeter itself.

While passive dosimetry ultimately provides a worker's dose of record, electronic dosimeters serve a complimentary role. They provide workers with real-time, precise updates and alarms, ensuring proactive awareness of their current radiological conditions. Mirion electronic dosimeters and accessories provide a stable platform for an effective radiation protection program and monitoring of workers' radiation exposure.

- ✓ 30+ years of industry experience
- ✓ Implemented in more than 90% of applicable North American utilities
- ✓ Innovation driven by user feedback
- ✓ Technically advanced, user-friendly design

ACCESSORIES

Mirion supplements our flagship electronic dosimeter line with a variety of useful tools that utilize advanced functionality to take advantage of our powerful dosimeters. These accessories can be as simple as dosimeter readers that interface with configuration software to manage settings, troubleshoot faults, and capture historical data. They can also be as complex as an automated calibrator that enables rapid setup of large populations in short order. Mirion dosimeter accessories help leverage the electronic dosimeter into a broadly useful asset, able to be quickly configured, assigned, and deployed.



DMC 3000™ DOSIMETER

With continuous improvement and technical innovation, the DMC 3000 dosimeter represents the culmination of over 30 years of industry expertise. The DMC 3000 device is a highly advanced electronic dosimeter that accurately measures X-ray and gamma exposure across a wide range of energies. The modular design allows for expanded capabilities such as enabling measurement of beta or neutron exposure, extremely low dose rates, and even wireless data transmission as a teledosimeter.



DMC 3000 Electronic Dosimeter with LTx module dedicated to Location and Telemetry

ADD-ON MODULES



Telemetry Module (Tx)



Location Telemetry Module (LTx)



Enhanced Telemetry Module (eTx)



Neutron Telemetry Module (NTx)



Neutron Module Hp10



Beta Module



Bluetooth® Low Energy Module

Dosimeters

DMC 3000™ Personal Electronic Dosimeter

The DMC 3000 dosimeter features a unique, high contrast and back-lit LCD display, enhanced alarms (audible, visual, and vibration alerting), high EMI and RF Immunity and long battery life.



FEATURES

NUCLEAR

- Display Units: mSv, μ Sv, or mrem
- Measurement Range (Dose): 0.01 mrem (0.1 μ Sv) to 1000 rem (10 Sv)
- Measurement Range (Dose Rate): 0.01 mrem/h (0.1 μ Sv/h) to 1000 rem/h (10 Sv/h)
- Energy Range (X-ray and Gamma): 15 keV to 10 MeV
- Energy Response: $\pm 20\%$ (typically 10% from 16 keV to 10 MeV)

ELECTRICAL

- Power Supply: Standard AAA (LR03) 1.5 V alkaline battery
- Battery Life: 1 year battery life with normal use*
* 0.1% of the time in alarm

OPERATIONAL

- Display: Large LCD with high quality white back-lighting eight alpha-numeric digit display
- Audible Alarm: Loud speaker (>85 db)
- Visual: Super bright forward facing alarm LED along with alarm and information LEDs on top
- Vibrating alarm
- Temperature range: 14 °F to 122 °F (-10 °C to 50 °C)
- Waterproof IP67
- Shock, vibration and drop resistant (1.5 meters on concrete)

MECHANICAL

- Dimensions: 3.4 x 2.2 x 0.8 in. (86 x 56 x 21 mm) without clip
- Weight (alkaline battery and clip): < 2.9 oz (84 g)



NEW

DMC 3000 Bluetooth® Module Connectivity Module for DMC 3000 Dosimeter

Designed to enable connectivity and enhance user safety, the Bluetooth module allows for the pairing of the DMC 3000 dosimeter to other devices and the transmission of dosimeter data to a telemetry network.

With the introduction of the Bluetooth module, Mirion Technologies is also pleased to release the MirionWatch™ device for improved alarm reporting and ConnectStudio™ software for efficient network management.



NEW

ConnectStudio™ Connectivity Management Software

ConnectStudio software helps strengthen exposure monitoring and supervision by enabling connectivity of the new DMC 3000 dosimeter with Bluetooth module, MirionWatch device, and the related ecosystem.

With ConnectStudio software, users can supervise paired dosimeters within a short-range telemetry network. An intuitive operational display supports local action based on telemetry feedback. In addition, ConnectStudio software can serve as a gateway to Mirion WRM network for a remote supervision through AWM radio.



Quick and easy check of dosimetry information at glance

NEW

MirionWatch™ Device for DMC 3000™ Bluetooth® Module

The MirionWatch device strengthens alarm alerting and reporting for personnel working in challenging environments.

Paired with the DMC 3000 dosimeter via our newly-released Bluetooth module, the MirionWatch device provides a wristband-based vibrational alert when an alarm threshold is met, acting as a reinforcement of the primary dosimeter alert. The vibrational alert is easily felt by the user, and an intuitive interface on the MirionWatch device displays alert details.

The MirionWatch device can fully integrate with the Mirion connected ecosystem (software and reader), offering a complete user experience.



DMCUser™ Electronic Dosimeters Management and Maintenance Software

DMCUser is the companion software to support operational electronic dosimetry management and maintenance in commercial nuclear, defense, homeland security and medical applications.

It allows full customization, configuration, maintenance and diagnostic of any dosimeters belonging to the DMC product line.

DMCUser software is compatible with a wide range of Mirion products as an integrated platform.



DMCUser Companion for DMC 3000

Additional DMC 3000 Dosimeter Add-On Modules



Telemetry Module (Tx)

The Telemetry Module combines with the DMC 3000 dosimeter to transmit the radiological data (accumulated dose, dose rate and alarm status) to other WRM2 Telemetry System components (Base Station, Repeater, etc.)



Location Telemetry Module (LTx)

Part of the Orion™ RTLS ecosystem, the purpose of the Location Telemetry (LTx) Module is to provide an additional real-time location feature and to transmit worker data (worker information, gamma radiological data and setpoints) to WRM Telemetry Systems.



Enhanced Telemetry Module (eTx)

The eTx is the latest state-of-the-art telemetry module for DMC 3000 dosimeter. This enhanced module is able to transmit worker's data (worker information, gamma radiological data and setpoints) to WRM3™ Telemetry System components.



Neutron Telemetry Module (NTx)

Neutron Telemetry Module provides an additional Neutron measurement and transmits worker's data (worker information, gamma and neutron radiological data and setpoints) to a WRM Telemetry System.



Neutron Module Hp10

The Neutron Module combines with the DMC 3000 dosimeter to measure Neutron radiation at a wide range of energy levels.



Beta Module

The Beta Module combines with the DMC 3000 dosimeter to measure the Hp(0.07) shallow dose radiation at a wide range of energy levels.

Dosimeter Accessories

Hands-Free Dosimeter Readers



LDM 320W™ and LDM 320D™ Hands-Free Dosimeter Reader

The LDM 320W and LDM 320D readers operate using software packages installed on the computer (PC) and communicate with the DMC 3000 and SOR families in hands-free data exchange mode.

FEATURES

OPERATIONAL

- Visual: Two-color electroluminescent diode for different indications
- Compatible with packages: DosiCare™, DosiFFR™, DMCUser™ and LDM 3000SW software
- Nominal Range:
 - DMC 2000 / SOR units: 9.8 in. (25 cm) max
 - DMC 3000 unit: 1.9 in. (5 cm) max

MECHANICAL

- Compatible with the DMC 2000 and SOR families, iPAM-Tx as well as the DMC 3000 dosimeter
- Operating Temperature: 0 °C to 50 °C (32 °F to 122 °F)
- Storage Temperature: -10 °C to 60 °C (14 °F to 140 °F)
- Humidity: 90% HR (without condensation)

ELECTRICAL

- Power Supply: Self powered through USB port

Dosimeter Calibrators

IRD 2000 Irradiator for Electronic Dosimeter Calibrations and Response Checking

The IRD 3000™ unit is a bench-top calibrator used for calibrating and calibration checking the DMC 3000 and SOR electronic dosimeters against a NIST traceable standard and to ensure ANSI compliance. The IRD 3000 unit, combined with a PC running the DosiCal software and a PC printer will automatically generate a calibration report for each dosimeter.

FEATURES

NUCLEAR

- Delivers a dose rate of approximately 300 mRem/h (3 mSv/h) within the shielded compartment
- Radiation Source - ^{137}Cs , 0.37 GBq (10 mCi) shielded source, very low external radiation at < 0.25 mR/h (2.5 $\mu\text{Sv/h}$)
- Automated measurement acquisition
- dosimeters at a time

OPERATIONAL

- Can calibrate up to three



Dosimeter Accessories

continued

Access Control



Passive Entry Turnstile

The Passive Entry Turnstile provides a dosimeter checkpoint that permits the workers to proceed and access the area if their dosimeter is turned on.

FEATURES

OPERATIONAL

- Visual: LED indicator lights

ELECTRICAL

- 110 V ac/50 Hz, 240 V ac/ 60 Hz switching

MECHANICAL

- Dimensions: 36 x 27 x 67 in. (91.4 x 68.5 x 170.2 cm)
 - Passage Space: 18 in. (45.7 cm)
 - Turnstile Arm: 1.25 in. diameter (3.17 cm)
- Weight: 130 lb (58.95 kg)
- Compatible with all DMC 2000/3000 and SOR Electronic Dosimeters
- Types: Right hand or left hand
- Fail safe and fail lock mechanical controls
- Portable size also available



RWP Turnstile Smart Safety Checkpoint

The RWP Smart Turnstile provides a dosimeter checkpoint that permits the workers to proceed and access the area if their dosimeter is turned on and they are on the correct RWP.

FEATURES

OPERATIONAL

- Display: Touch screen tablet computer for visual verification/ acknowledgement by access personnel. Remote (Desktop) configuration if the Turnstile is on a PC network
- Visual: LED indicator lights (Amber and Green)

ELECTRICAL

- Power Supply: DC Fan
 - Four outlet surge protector
- 110 V ac/50 Hz, 240 V ac/ 60 Hz switching
- Outputs: +5 V; +24 V; +15 V; -15 V (not used for this application)

MECHANICAL

- Portable Dimensions: 21 x 27 x 38 in. (53.3 x 68.6 x 96.5 cm)
- Full Size Dimensions: 36 x 27 x 39 in. (91.4 x 68.5 x 99.1 cm)
 - Passage Space: 18 in. (45.7 cm)
 - Turnstile Arm: 1.25 in. diameter (3.17 cm)
- Weight: 140 lb (63.5 kg)
- Types: Right hand or left hand
- Fail safe and fail lock mechanical controls

LDM 3200™ RCA Entry/Exit Reader

LDM 3200 unit is an Electronic Dosimeter self issue reader used to enter and exit radiological controlled areas. Compatible with HIS-20 WACS, DosiServ software. The unit is equipped with a multilingual touchscreen. At the area entry, the LDM 3200 unit allows the worker to fill in the data requested by the dosimetry system and to activate the dosimeter. At the area exit, the reader acquires the dosimeter data and transfers it to the dosimetry system. It is compatible with all Mirion dosimetry systems and can be used with all LDM readers. It offers the capability to adapt to a site-specific badge reader or NFC reader.

FEATURES

OPERATIONAL

- Display: 10.1 in. touchscreen
- Windows 7 system
- Dosimeter sleeve compatible with DMC 2000 and DMC 3000 modules

ELECTRICAL

- 100-240 V ac~ 4 A 50-60 Hz (0.5 A - 220 V ac) or 9-36 V dc (5A - 12 V dc) (optional)

MECHANICAL

- Dimensions: 20.7 x 16 x 6.50 in. (525 x 405 x 165 mm)
- Weight: 29.8 lb (< 13.5 Kg)
- Desktop or Wall mountable



LDM 1000™ RCA Entry/Exit Reader

The LDM 1000 reader is dedicated to the control access of radiological areas. At the entrance of the controlled area, the LDM 1000 allows the user to fill in the data required by the dosimetry system and to activate the dosimeter. At the exit of the controlled area, the reader acquires dosimeter data and transfers it automatically to the dosimetry system.

FEATURES

OPERATIONAL

- DosiServ and DosiCare software compatible for access control mode

ELECTRICAL

- Power supply 110 – 230 V ac
- Input voltage range: from 85 V to 264 V ac
- Input voltage frequency: 50 or 60 Hz
- Minimum recommended wire section: 0.75 mm²
- Voltage regulator: 2 A

MECHANICAL

- Compatible with DMC 2000, DMC 3000, SOR/R modules
- LDM 1000i:
 - 315 x 216 x 104 mm (H x W x D)
 - Weight: 2.1 kg
- LDM 1000:
 - 315 x 216 x 122 mm (H x W x D)
 - Weight: 4.2 kg



Telemetry

The AWM™ Adaptive Wireless Monitor represents a paradigm shift in Mirion's approach to wireless remote monitoring.

In the past, wireless monitoring required an array of different devices under the same family umbrella that each performed overlapping, but specific, roles. In contrast, the AWM unit is a single device that fulfills many roles. The instrument can serve as a base transceiver or a repeater, it features a color display for monitoring status and configuration, and it connects to the site LAN via any number of interface options including USB, network connection, or WiFi. The AWM device eliminates complexity in establishing and maintaining a wireless monitoring system and allows RP personnel to focus their efforts on the data being gathered and interpreted, rather than setup of the system.

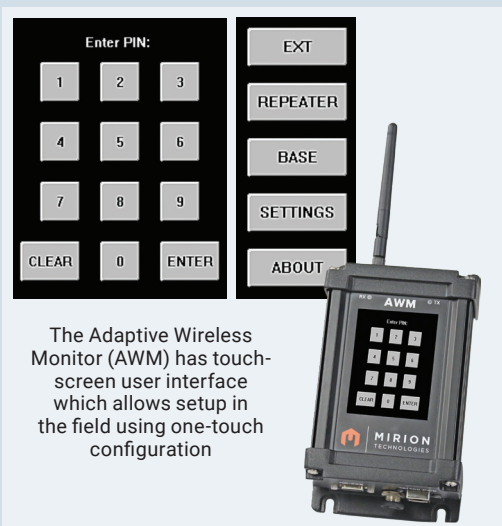

The Adaptive Wireless Monitor (AWM) has touch-screen user interface which allows setup in the field using one-touch configuration

- ✓ Deployed throughout the industry for over 20 years
- ✓ Helps reduce RP personnel radiation exposure during job coverage
- ✓ Ensures consistent information for all decision makers
- ✓ Unparalleled reception range and system flexibility

Section 2

The AWM unit brings together Mirion's wide range of products, enabling wireless functionality across the board – whether covering personnel on a job, monitoring areas, receiving air samples and survey data, or making the data available to multiple departments through the site LAN with TeleView 3000 software.





AWM™ Adaptive Wireless Monitor

The AWM monitor is a dynamic technology that represents an all-in-one solution for teledosimetry. This compact system can be deployed as a base station, repeater, EXT, active dive repeater, etc.; which minimizes the different types of inventory that must be maintained. It connects to software via RS-232, USB, Ethernet or WiFi. Complete with an onscreen configuration for user defined needs and also the ability to be powered by PoE.

FEATURES

OPERATIONAL

- Display: On-screen configuration
- WRM2, WiFi, Bluetooth, and GPS enabled
- Power over Ethernet
- WRM2 Radio 900 MHz or 2.4 GHz frequency

MECHANICAL

- Dimensions: 7.1 x 4.1 x 2.25 in. (180 x 104 x 57 mm)
- Adaptable to interface with a wide range of radiation monitors

ELECTRICAL

- Battery Life: > 24 hr battery backup



Active Dive Antenna for Teledosimetry Data Transmission

The revolutionary Active Dive Antenna has built on the functionality of the original Dive System by providing its own WRM2 radio within the antenna paddle. The Active system doesn't just transfer the WRM2 signal through the cable, it provides a POWERED BROADCAST of the signal – easily overcoming any loss potential. The Active Dive System is ideal for higher frequencies and longer cable lengths. Each diver's teledosimetry data is broadcast on their own "closed loop" which means RP personnel can monitor multiple divers simultaneously without experiencing interfering crosstalk between the divers.

FEATURES

OPERATIONAL

- WRM2 Radio 900 MHz or 2.4 GHz frequency
- Compatible with WRM2 Base Stations, MeshRepeaters, etc.
- Eliminates Crosstalk Interference with multiple divers simultaneously in the water

ELECTRICAL

- Antenna power is provided by the AWM (typically DC)

MECHANICAL

- Housing:
 - Waterproof (AMP-type) cable
 - Waterproof Antenna up to 100 ft depth
- Up to 400 ft (91.4 m) standard AMP cable
- Externally connected to diver – does not breach dry dive suit

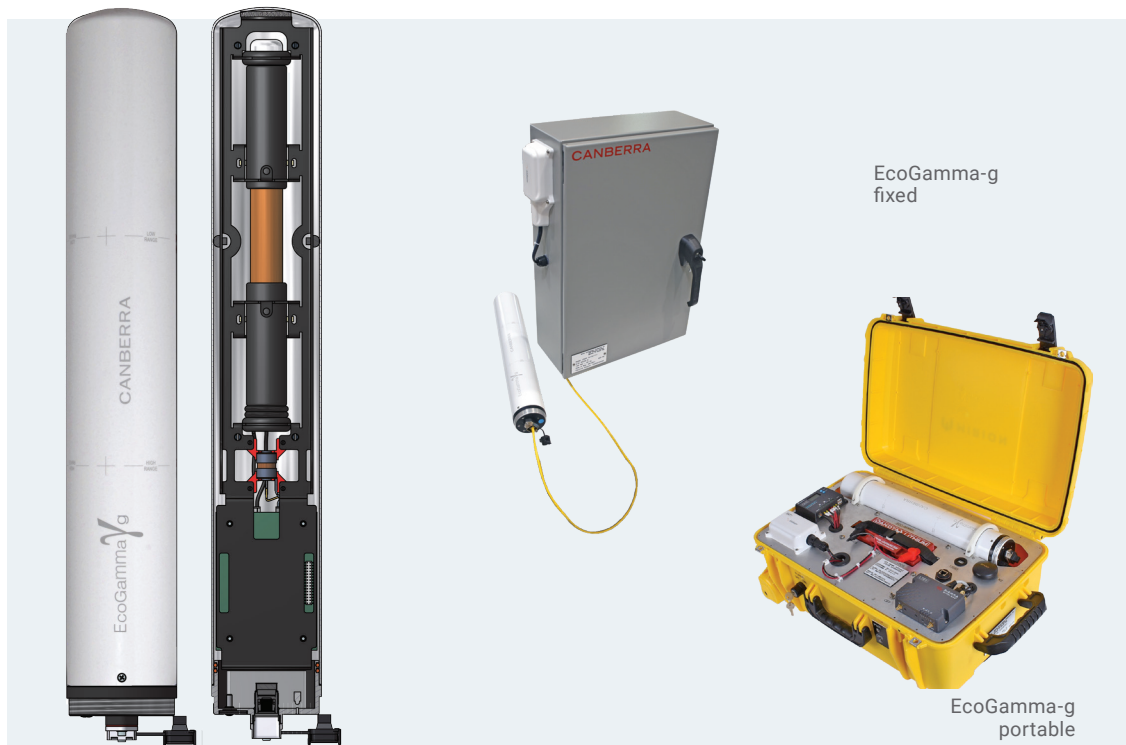

EcoGamma™-g Environmental Gamma Radiation Monitor

The EcoGamma-g monitor logs all data including dose rates, detector status, count rates, alarms, and faults. The monitor is an advanced, dual detector, environmental gamma radiation monitor designed to operate in the most extreme conditions with unsurpassed accuracy, range and stability.

FEATURES

NUCLEAR

- 10 nSv/hr (1.0 µR/hr) to 10 Sv/hr (1000 R/hr). Linearity ±10% referenced to Cesium-137
- Evaluated to 100 Sv/hr (10 000 R/hr)
- Two Geiger Mueller Detectors
 - Crossover on increasing dose rate: 500 mR/h (5 mSv/hr)
 - Crossover on decreasing dose rate: 300 mR/h (3 mSv/hr)

OPERATIONAL

- Operating temperature range: -40 °C to +60 °C (-40 °F to +140 °F)
- Operating humidity: 0 to 100%

ELECTRICAL

- Power over Ethernet (PoE) 1.25 watts
- Power over USB 0.5 watts

MECHANICAL

- Construction: Cylindrical Aluminum, IP67 enclosure
- Threaded mounting base
- Size: 467.86 mm (18.42 in.) length; 76.2 mm (3.0 in.) diameter
- EMC: Tested to IEC 61010-1:2001 (Second Edition)/EN 61010-1:2001
- Weight: 1.1 kg (2.4 lb)

ALERT INDICATORS

- Dual color LED

Orion™ Real-Time Location System

Bringing real-time location and radiation measurement data together in a seamless experience for nuclear power, industrial and research facilities.

SYSTEM COMPONENTS

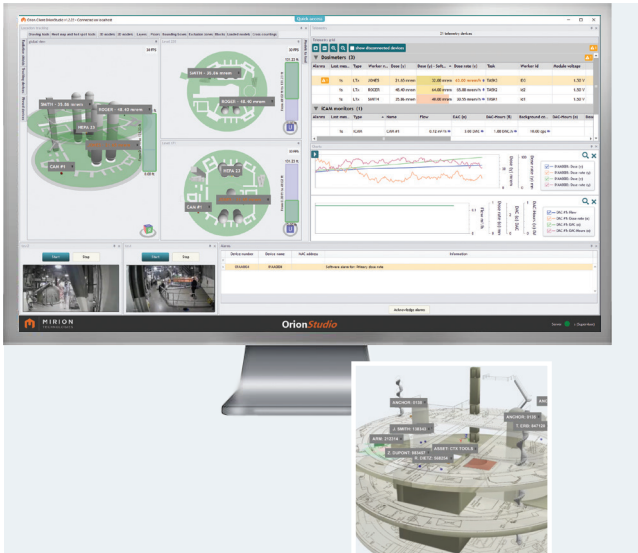

Orion Studio Software

Orion Studio is a client/server software solution that integrates the WRM radiological data (Dose, Dose Rate, Alarm Conditions, Airborne Concentration, flow rates, temperature, voltage, ppm/ppb, etc.) within 2D or 3D views. A customizable display layout can be prepared for specific areas of interest/focus to permit multiple operators to effectively cover individuals or work teams engaged in high-hazard tasks.

FEATURES

- Location tracking of dosimetry with real-time radiological data
- Location tracking of telemetry enabled radiological measurement instruments with real-time data
- Messaging to dosimeter, i.e., Contact RP or Leave Area
- Track other dose rate and area monitoring devices
- Asset and critical component location tracking
- Remote monitoring for area dose rate and other transmitting devices
- 2D and 3D Map Visualization of monitored areas
- Real-time geofencing/exclusion area monitoring
- Supports asset boundaries to alert removal from the monitored location
- Radiological data consolidation into dose rate heatmaps
- Virtual cross-boundary monitoring (counting in/out of areas)
- Supports location tracking and data visualization for Mirion and many other continuous air monitors
- Client/Server Deployment
- Operator ability to select specific regions of interest for visualization
- Operator ability to define specific areas or working groups to monitor
- Rapid identification of radiological alarm locations
- Visualization of specific teams or focus areas for job coverage
- IP Camera Support



Orion Anchor

The Orion Real-Time Location System supports Critical Path activities by providing position data for compatible devices (e.g., Dosimeters and Asset Tags). Anchors are placed throughout the monitored area to capture and relay location data for visualization on a monitoring station. Installation is simple, using a daisy chain RJ45 configuration with Power Over Ethernet (PoE) connections. For temporary mounting installations, anchors have an available magnetic mount for rapid deployment and removal.

FEATURES

- Ultra-Wideband enabled RF communication
- PoE enabled functionalities
- IPv4 networking
- Daisy Chainable network connections for power and communications from one PoE+ port
- Available wall or ceiling mounts
- Energy consumption: 120 V, 60 Hz; 230 V, 50 Hz via -48 V dc PoE
- Frequency: 6.5 GHz nominal
- Weight: 0.8 kilograms with drip cover (0.4 without drip cover)
- Temperature range: -10 °C to 50 °C (14 °F to 122 °F)
- Shock, vibration and drop resistant

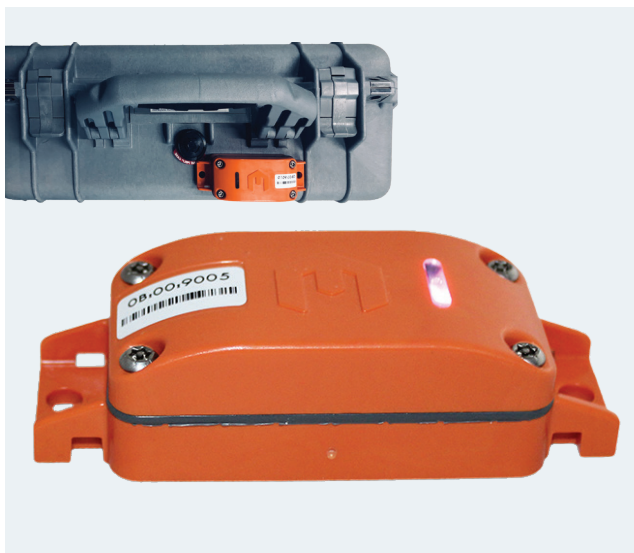

Orion Asset Tag

Asset tags are a key component of the Orion system, allowing facilities to track the location of essential tools and equipment throughout a monitored facility. The tag transmits location data, eliminating challenges caused by lost equipment. Asset tags are rugged, watertight and offer a two-year battery life.

The Orion RTLS Asset Tag actively communicates by ultra-wideband to other integrated Orion products to track the location of equipment and assets. Asset Tags are associated with equipment names/ID in the Orion Studio Software and location tracking can be used to monitor last storage location or unauthorized movement.

FEATURES

- Rugged and watertight
- One-meter location accuracy
- Two-year battery life with AA alkaline batteries
- IP65 Rating (Immersion)
- Small form factor module: 4.25 x 1.60 in. (110 x 40 mm)
- Tri-color LED indicator for user-friendly status indication
- Versatile mounting of the asset tag for permanent installation
- Temperature range: -10 °C to 50 °C (14 °F to 122 °F)
- Storage: -20 °C to 71 °C (-4 °F to 160 °F)
- Shock, vibration and drop resistant



Location Telemetry Module (LTx)

Orion RTLS enhances the established technology of the DMC 3000 dosimeter when fitted with an LTx module. The LTx module supports the transmission of WRM radiological information and location coordinates, tracking the wearer's location. The dosimeter, with the LTx module, communicates dose rate and location data with Orion Studio Software to facilitate real-time visualization.

FEATURES

- Allows direct connection to existing populations of DMC 3000 dosimeters (G3 Version 7.8.x or greater)
- Integrates directly with the dosimeter
- Workers do not need to wear separate cards or equipment for transmission of location tracking data
- Communicates with both Orion RTLS anchors and existing WRM systems
- Configurable for the WRM3 Protocol allowing it to transmit the DMC thresholds, wearer name, ID, RWP and task
- Omnidirectional Antenna for the Ultra-Wideband (UWB) Technology used for accurate tracking
- Transmits radiological information in pre-configured intervals to WRM receivers
- Independent module power supply: AAA battery
- Designed for ruggedness and durability
- Waterproof IP67 (1 m per 1 hour)

Portable Radiation Measurement

Mirion offers dose rate and survey meters for a wide range of users and probes to suit many applications.

- ✓ Multi-purpose meters meet a variety of applications
- ✓ Smart add-on probes allow flexible deployment
- ✓ Integrated wireless functionality across the product line
- ✓ Rugged, dependable, accurate, and easy to use

Generally, health physics users like to invest in one particular instrument so training and expertise can be maximized. Mirion offers handheld instruments for all levels of users, from the technician performing a specific task on site to the highly knowledgeable health physicist. These instruments are focused on particular applications and can be used either as handheld, semi fixed or fixed devices.

With the CSP™ Smart Probe approach, the instrument is selected to match the situation specifics, taking into account that any CSP probe will always be compatible.

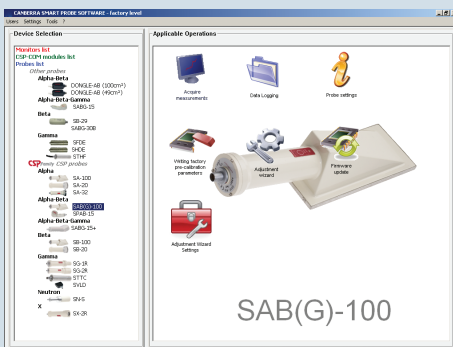

- ✓ More instruments are available in the field
- ✓ Considerably less calibration and set-up time
- ✓ 100% compatibility with all instruments
- ✓ Reduced total cost of ownership and daily workload
- ✓ Reduced need for paper and log books
- ✓ Improved accuracy of data transcription



RDS-32
Modular Radiation
Survey Meter



Tele-STTC-2™ Wide Range Gamma Telescopic Probe

The compact size, exceptionally lightweight, and easy-to-deploy mechanism of the Tele-STTC-2 probe makes this an ideal tool for measurement of areas that are difficult to access or require remote measurement high exposure areas.

FEATURES

- Telescopic pole with H*(10) ambient gamma dose equivalent rate measurement probe
- Gamma dose rate measurement up to 10 Sv/h (1000 rem/h)
- Energy-compensated Geiger Mueller detector
- Remote measurement up to 4.09 m (13.4 ft)
- Compact size when folded
- Extremely lightweight and rugged
- Integrated cable for meter
- Calibrated via a personal computer (PC) which enables the direct generation of electronic format calibration data. Eliminates the need for paper and transcription errors



Tele-STTC-2
Telescopic Probe
with RDS-32 meter.
Also fits the
Colibri meters.

Portable Survey Meters



RDS-32™ Modular Radiation Survey Meter

RDS-32 device is a multipurpose survey meter with internal detector and optional externally connected probe. The RDS-32 meter is a complete solution that can be used for handheld surveillance, personal monitoring and as an area radiation monitor.

NUCLEAR

- Display Units: rem(/h), Sv(/h)
- With External Detector: rem/h, Sv/h, cps, cpm, Bq, Bq/cm² and dpm
- Detectors: One energy-compensated GM tube, energy response according to ambient dose equivalent H*(10)
- Measurement Range (Dose rate): 0.05 μSv/h (5 μrem/h) to 100 mSv/h (10 rem/h)

OPERATIONAL

- Display: 128 x 64 pixel
- Keyboard: 4 navigation keys and a select key
- Flexible histogram functions
- Real-time clock function

ELECTRICAL

- Power Supply: Two AA size batteries (alkaline or NiMH)
- Battery Life: ~600 hr at normal background

MECHANICAL

- Housing: IP67 Waterproof
- Dimensions: 3.93 x 2.63 x 1.29 in. (100 x 67 x 33 mm)
- **Weight:** RDS-32: 0.35 lb without batteries (160 g), with batteries (210 g), 0.46 lb (0.37 lb) without batteries, 220 g (0.49 lb) with batteries



RDS-32 WR Wide Range Module Radiation Survey Meter

RDS-32 Wide Range device is a multipurpose survey meter with internal detector survey meter with dual detectors (GM and SD) and optional externally connected probe. The RDS-32 WR unit is a complete solution that can be used for handheld surveillance, personal monitoring and as an area radiation monitor.

NUCLEAR

- Display Units: rem(/h), Sv(/h)
- With External Detector: rem/h, Sv/h, cps, cpm, Bq, Bq/cm² and dpm
- Detectors: One energy-compensated GM tube and one Silicon Pin diode energy response according to ambient dose equivalent H*(10)
- Measurement Range (Dose rate): 0.05 μSv/h (5 μrem/h) to 10 Sv/h (1000 rem/h)

- Keyboard: Four navigation keys and a select key
- Flexible histogram function
- Real-time clock function

ELECTRICAL

- Power Supply: Two AA size batteries (alkaline or NiMH)
- Battery Life: ~600 hr at normal background

MECHANICAL

- Housing: IP67 Waterproof
- Dimensions: 3.93 x 2.63 x 1.29 in. (100 x 67 x 33 mm)
- **Weight:** RDS-32 WR: 195 g (0.43 lb) without batteries
RDS-32iTx WR: 205 g (0.45 lb) without batteries, 255 g (0.56 lb) with batteries

OPERATIONAL



Download the Mirion apps to connect your RDS-32™ meter and AccuRad™ PRD to SpirVIEW Mobile™ Supervisory Software and the RadResponder Network



RDS-30™ Radiation Survey Meter

The RDS-30 device is a digital handheld dose rate meter designed for a wide range of gamma and X-ray radiation surveillance applications. The RDS-30 unit is simple-to-use, compact, lightweight and waterproof with reliable and accurate performance and a friendly user interface.

FEATURES

NUCLEAR

- Measurement Range (Dose): from 1 μ rem to 100 rem (0.01 μ Sv to 1 Sv)
- Measurement Range (Dose rate): from 1 μ rem/h to 10 rem/h (0.01 μ Sv/h to 100 mSv/h)

ELECTRICAL

- Power Supply: Two alkaline batteries IEC LR6/AA size (recommended)
- Battery Life: > 2000 hr at normal background with alkaline cells

MECHANICAL

- Housing: IP67 Waterproof



RDS-80™ Contamination Survey Meter

The RDS-80 Surface Contamination Meter is a versatile contamination detector which has been designed for a wide range of applications in different fields of radiation protection in nuclear industry, rescue and other operations, involving a possibility for abnormal contamination levels.

FEATURES

NUCLEAR

- Measurement Range: Surface contamination 1 to 100 000 cps, 0.01 to 1 000 000 Bq/cm² or 1 to 1 000 000 DPM
- Surface activity (Bq/cm²) display configurable for different isotopes

ELECTRICAL

- Power Supply: Two alkaline batteries IEC LR6/AA size (recommended)
- Battery Life: > 2000 hr at normal background with alkaline cells

MECHANICAL

- Housing: IP67 Waterproof



AccuRad™ PRD Personal Radiation Detector

A discreet yet robust gamma radiation detecting PRD designed for law enforcement, fire rescue, and other emergency responders to detect and interdict nuclear and radioactive materials. It also provides dose measurement and alarming capabilities for event response.

FEATURES

NUCLEAR

- CsI(Tl) scintillation detector with temperature compensated SiPM for interdiction missions
- Silicon diode for integrated dose and high dose rate to ensure proper health and safety

ELECTRICAL

- Two AA batteries for more than 900 hours of continuous operation
- Tool-less battery cover

MECHANICAL

- Innovative heavy-duty bi-material construction
- Compliant with ANSI N42.32-2016 and IEC 62401:2017



Portable Survey Meters

continued



AVIOR®-2 Desktop Dose-Rate and Survey Meter

The AVIOR-2 unit is a versatile alarm desktop, portable or wall mounted dose-rate and survey meter for the contamination control and dose-rate assessment.

FEATURES

NUCLEAR

- Units Displayed (depending on probe): c/s, Bq_{eq}, Bq_{eq}/cm², Sv/h, Sv_{eq}/h, rem/h, cpm; dpm and dpm/100cm²
- Alarm Threshold:
 - CSP probe 10 values for each unit to display, stored in probe memory. Each value is editable via PC setup CSPS™ software or directly on AVIOR-2 unit
- Response Time
 - As fast as 1/4 s for bargraph display depending on probe, on a semi-logarithmic scale
 - 1 s for smoothed digital readout display

ELECTRICAL

- Built-in rechargeable Li-ion battery pack
- Battery Life with Backlight: (Maximum/turned off): 31/70 hr one SAB-100 unit connected, 29/60 hr with SA-100 and SB-100 units connected
- Built-in charger
- Universal Mains power input, 100 - 240 V ac, 50/60 Hz. Rear-panel IEC-type connector. Cordset included
- Display of remaining charge with battery pictogram

MECHANICAL

- Housing: Molded rugged Polycarbonate
- Dimensions: 7.2 x 4.1 x 4.1 in. (184 x 105 x 105 mm) (L x W x H)
- Weight: 33.5 oz (950 g), battery included
- Connector for External Probes: S 104 A066 137+ Fisher socket (CSP probe)

Colibri® TTC & Colibri VLD Hand-Held Health Physics Communication ALARA* Platform

Colibri unit is a comprehensive health physics instrument with unique characteristics that can lower the dose exposure of HP technicians and other workers in radiation areas. The “always on” gamma dose feature ensures the worker is always informed – even when using the Colibri unit for contamination surveys with attached probes. The Colibri device also allows for wireless data collection from pre-positioned detectors that can be placed in radiation areas – eliminating the need to attach probes, get close to the source – then manually transcribe data. Walk into the room – and the Colibri unit performs the survey for you – allowing exit from the rad area in a fraction of the normal time.

FEATURES

NUCLEAR

- Display Units: Internal Detector: Sv/h, Sv or rem, rem/h. H*(10) ambient gamma dose equivalent rate (according to ICRP-60)
- Detector: TTC: Energy Compensated Geiger Mueller. VLD: CsI(Tl) with energy compensation
- Sensitivity: (¹³⁷Cs) – TTC: 0.73 c/s per μ Sv/h (438 cpm per mR/h), VLD: 70 c/s per μ Sv/h (27 kcpm per mR/h)
- Measurement Range: TTC: 0.05 μ Sv/h to 10 Sv/h (5 μ rem/h to 1000 rem/h), VLD: 10 nSv/h to 1 mSv/h (1 μ rem/h to 100 mrem/h)

OPERATIONAL

- Display: 3.5 in. QVGA TFT 240*320 with backlight
- Audible Alarm – >85 dB at 30 cm, typical: 90 dB
 - Vibrator
 - Flashing red LED, alarm pictogram and screen display color (red)

ELECTRICAL

- Batteries: Integrated rechargeable batteries (Li-ion)
- External Charger: 100-240 V ac/47-63 Hz
- Charge Time: 2 hr approx.
- Battery Life: Up to 25 hr (based on TTC version); display of ‘low battery’ pictogram when battery life is < 1 hr

MECHANICAL

- Housing: Molded polycarbonate housing with elastomer and Silicon keyboard. Waterproof and easy to decontaminate
- Dimensions: 7.6 x 3.9 x 2.7 in. (195 x 100 x 69 mm) (L x W x H)
- Weight: 22.2 oz depending on version and options (~630 g)
- Connector for Probes: Waterproof Fisher socket



Colibri-TTC Meter



Colibri-VLD Meter

*ALARA = As Low As Reasonably Achievable

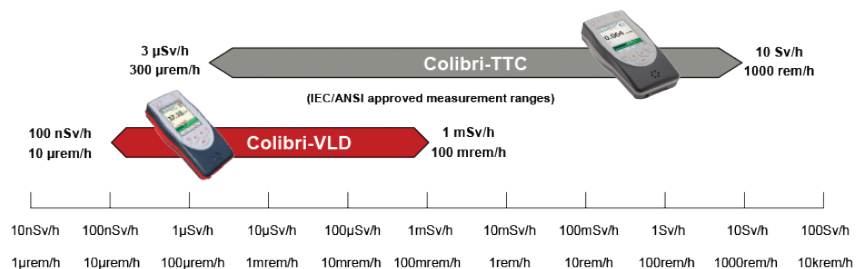

Contamination and Dose-rate Survey Probes

External RDS-31/32 Gamma Probes



GMP-12SD™ External Gamma Probe

The GMP-12SD probe is used as an externally connected detector to the RDS-31/32 family of multipurpose meters and intended for long-term monitoring of high dose rate applications.

FEATURES

NUCLEAR

- Detector: Silicone PIN diode
- Measurement Range (Dose rate): 1 mrem/h (10 μ Sv/h) to 1000 rem/h (10 Sv/h)
- This probe does not have internal memory to allow a high amount of absorbed dose (90 krem (900 Sv) total exposure)
- While not a smart probe the calibration for this probe can be uploaded to allow use on the meter

MECHANICAL

- Housing: IP67 Waterproof
- Dimensions:
 - Length: 6.9 in. (177 mm)
 - Cylinder diameter: 1.37 in. (35 mm)
- Weight: 0.88 lb (400 g)



GMP-12UW™ External Gamma Probe

The GMP-12UW probe is used as an externally connected detector to the RDS-31/32 family of multipurpose meters and intended for long-term monitoring of high dose rate applications. It is the same detector as the GMP-12SD except it has a weighted cap and is rated for underwater applications.

FEATURES

NUCLEAR

- Detector: Silicone PIN diode
- Measurement Range (Dose rate): 1 mrem/h (10 μ Sv/h) to 1000 rem/h (10 Sv/h)
- This probe does not have internal memory to allow a high amount of absorbed dose (90 krem (900 Sv) total exposure)
- While not a smart probe the calibration for this probe can be uploaded to allow use on the meter

MECHANICAL

- Housing: IP68 Waterproof (tested to 3 Atmospheres)
- Dimensions:
 - Length: 7.2 in. (185 mm)
 - Cylinder diameter: 1.37 in. (35 mm)
- Weight: 0.99 lb (450 g) with submersing weight



GMP-12GSD™ External Wide Range Gamma Probe

The GMP-12GSD probe is intended for monitoring gamma and X-ray radiation. It has been designed to fulfill both the civil defense and industrial applications requirements. GMP-12GSD unit is a "smart" probe, having an internal high voltage generator and non-volatile memory for calibration coefficients and probe identification data.

FEATURES

NUCLEAR

- Detector: GM Tube and Silicone PIN Diode
- Measurement Range (Dose rate): 10 μ rem/h (0.1 μ Sv/h) to 1000 rem/h (10 Sv/h)

MECHANICAL

- Housing: IP67 Waterproof
- Dimensions:
 - Length: 8.2 in. (208 mm)
 - Cylinder diameter: 1.37 in. (35 mm)
- Weight: 0.49 lb (220 g)

External RDS-31/32 Alpha/Beta/Gamma Probe



GMP-25™ External Alpha/ Beta/Gamma Probe

The GMP-25 unit is a Smart Frisker probe, used as an externally connected detector to the RDS-32 family of multipurpose meters. It is intended for routine alpha/beta/gamma contamination monitoring.

FEATURES

NUCLEAR

- Detector: GM tube 7313
- This is a Smart Probe which allows the Efficiency to be stored in the memory to allow any probe to be used by any RDS-32 meter. Also with the efficiency stored in the probe, the meter reads out in activity (dpm) not count rate

MECHANICAL

- Housing: Durable ABS/polycarbonate
- Dimensions:
 - Length: 14.8 in. (375 mm)
 - Width: 2.75 in. (70 mm)
- Weight: 1.08 lb (490 g)



RDS-32™ Telescope for External Probes

The RDS-32 meter and probes can be easily mounted/dismounted to/from the telescopic pole for standard radiation protection applications.

FEATURES

NUCLEAR

- Radiation detected: gamma and X-rays, 48keV...3MeV. Alpha & Beta radiation with external probes
- Detectors: one energy-compensated GM tube, energy response according to ambient dose equivalent $H^*(10)$
- Dose rate measurement range: 0.01 $\mu\text{Sv/h}$...0.1 Sv/h or 1 $\mu\text{rem/h}$...10 rem/h
- Dose measurement range: 0.01 μSv ...10 Sv or 1 μrem ...1000 rem
- Resolution: three significant digits or 0.01 $\mu\text{Sv/h}$ on dose rate and 0.01 μSv on dose (1 $\mu\text{rem/h}$ on dose rate and 1 μrem on dose)

MECHANICAL

- Length retracted 1118 mm and 3890 mm extended without the probe
- Length retracted 1415 mm and 4120 mm extended with the probe attached
- Telescope diameter 38 mm max, divided in four sections approx. 1 m each
- Weight of the pole 1.21 kg without RDS-31 meter and probes



RDS-32™ Radiation Monitoring Alarm Box

The RDS-32 Alarm Monitor is intended for stationary or fixed installation in premises where people may be exposed to ionizing radiation.

FEATURES

NUCLEAR

- Radiation detected: gamma and X-rays, 48keV...3MeV. Alpha & Beta radiation with external probes
- Detectors: one energy-compensated GM tube, energy response according to ambient dose equivalent $H^*(10)$
- Dose rate measurement range: 0.01 $\mu\text{Sv/h}$...0.1 Sv/h or 1 $\mu\text{rem/h}$...10 rem/h
- Dose measurement range: 0.01 μSv ...10 Sv or 1 μrem ...1000 rem
- Resolution: three significant digits or 0.01 $\mu\text{Sv/h}$ on dose rate and 0.01 μSv on dose (1 $\mu\text{rem/h}$ on dose rate and 1 μrem on dose)

MECHANICAL

- Casing EPDM and Polyurethane, IP 65/IK 08/07
- Transparent cover for meter's display and alarm
- Size: 6.3 x 5.3 x 6.5 in (160 x 134 x 166 mm)
- Temperature:
 - -25 °C...+60 °C (-40 °F to 140 °F), operating temperature
 - -40 °C...+70 °C (-40 °F to 158 °F), storage temperature

Contamination Probes

continued

CSP™ Smart Contamination Probes

Our probes offer handheld instruments for all levels of users, from the technician performing a specific task on site to the highly knowledgeable health physicist. These instruments are focused on particular applications and can be used either as handheld, semi fixed or fixed devices. With CSP Smart approach, the instrument is selected to match the situation specifics, taking into account that any CSP probe will always be compatible with the RDS-32, AVIOR meters, etc.

DOSE-RATE PROBE RANGE

<p>SABG-15+™ GM Pancake</p>  <p>Multipurpose 15 cm² contamination probe</p> <p>α β γ</p>	<p>SPAB-15™ PIPS® Detector</p>  <p>Alpha /beta discrimination in high gamma background (15 cm²)</p> <p>α β</p>	<p>SB-32™ Plastic Scintillator</p>  <p>32 cm² beta contamination check in high gamma background</p> <p>β</p>	<p>SVLD™ Energy Compensated CsI(Tl)</p>  <p>Very low H*(10) dose equivalent rate probe for public working area checks</p> <p>γ</p>	<p>SA-32™ ZnS Scintillator 32 cm²</p>  <p>Personal alpha contamination probe</p> <p>α</p>	<p>SA-100™ ZnS Scintillator 100 cm²</p>  <p>Large area alpha contamination check</p> <p>α</p>
<p>SB-100™ Plastic Scintillator 100 cm²</p>  <p>Large area beta contamination check</p> <p>β</p>	<p>SAB(G)-100™ Plastic/Zn-S Phoswich 100 cm²</p>  <p>Alpha/beta discrimination on large contamination area and personal frisking</p> <p>α β</p>	<p>SAB-32™ Plastic/ZnS Phoswich</p>  <p>Alpha/Beta discrimination for personal frisking</p> <p>α β</p>	<p>SG-1R™ NaI(Tl) Scintillator 1" x 1"</p>  <p>Low dose-rate and gamma contamination probe</p> <p>γ</p>	<p>SG-2R™ NaI(Tl) Scintillator 2" x 2"</p>  <p>Very low dose-rate and gamma contamination probe</p> <p>γ</p>	<p>SX-2R™ NaI(Tl) Scintillator 1.5" x 3 mm</p>  <p>Low energy gamma and alpha contamination check in humid environment</p> <p>α, X, γ</p>
<p>SN-S™ Moderated Helium 3 Tube</p>  <p>Neutron presence detection</p> <p>η</p>	<p>STTC™ Energy compensated G-M Detector</p>  <p>Wide range H*(10) dose rate equivalent to ICRP-60</p> <p>γ</p>	<p>SN-D-2™ Moderated Helium 3 Tube</p>  <p>Neutron dose equivalent rate</p> <p>η</p>			

CSP Probes – Alpha Only

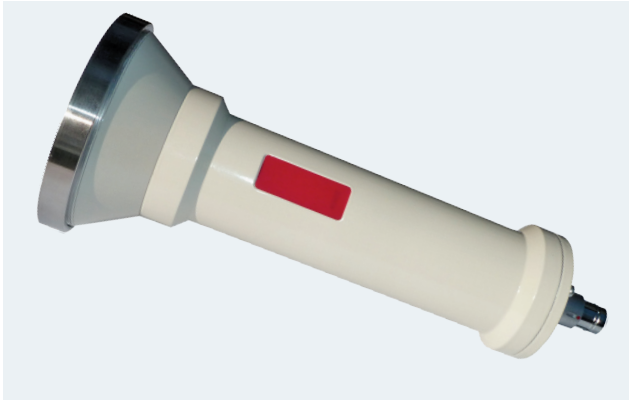

SA-32™ CSP Alpha Contamination Probe

FEATURES

NUCLEAR

- Display Units: Depending on survey meter (c/s, Bq, Bq/cm² with SI CSP instrument and CPM, DPM, DPM/100 cm² with American CSP instruments)
- Emitters: Alpha
- Detector: ZnS(Ag) coating on 3 mm thick neutral plastic material
 - Detection area: 32 cm² (total diameter = 70 mm, sensitive diameter = 64 mm)
 - Adhered aluminium/Mylar film on detector entrance surface, thickness: 1.8 µm
 - Protection grid transparency: 89%
- Measurement Range: 0 to 10 000 c/s, 0 to 600 kcpm. Activity equivalent range depends on calibration emitter. Conversion coefficient is factory set with ²³⁹Pu
- Dead Time: 50 µs
- Energy Range: Alpha > 3 MeV
- Surface Detection Uniformity: better than 50% of the highest efficiency point
- Gamma Sensitivity (¹³⁷Cs): < 0.0001 c/s/µSv/h
- Neutron Sensitivity (²⁵²Cf): < 0.002 c/s/µSv/h
- Background:
 - Ambient ≤ 100 nSv/h (10 µR/h): < 0.01 c/s (< 0.6 cpm)
 - Beta influence (⁹⁰Sr-⁹⁰Y): < 0.01%

MECHANICAL

- Housing: Painted aluminum
- Protection Grid: Stainless steel
- Dimensions: Length (with connector) x diameter (detector) x diameter (body): 225 x 85 x 55 mm (8.8 x 3.3 x 2.2 in.)
- Weight: 24 oz (678 g) without cable



SA-100™ Alpha Probe

FEATURES

NUCLEAR

- Display Units: Depending on survey meter (c/s, Bq, Bq/cm² with IS units survey meters and CPM, DPM, DPM/100 cm² with US units survey meters)
- Emitters: Alpha
- Detector: ZnS(Ag) adhered to 0.25 mm thick neutral plastic material
 - Detection area: 102 cm² (68 x 150 mm)
 - Removable aluminized Mylar entrance window on metallic frame, thickness: 6 µm
 - Protection grid transparency: 80%
- Measurement Range: 0 to 10000 c/s, 0 to 600 kcpm. Activity equivalent range depends on calibration emitter. Conversion coefficient is factory set with ²³⁹Pu
- Dead Time: 50 µs
- Energy Range: Alpha > 3 MeV
- Background: Ambient ≤ 100 nSv/h (10 µR/h): < 0.01 c/s (< 0.6 cpm)
- Sunlight Effect: No effect up to 80000 lux.
- Cross Talk: Beta to Alpha (⁹⁰Sr-⁹⁰Y) < 0.01%

MECHANICAL

- Housing: Painted aluminum
- Dimensions: Length (with connector) x width (detector) x height (detector): 12.3 x 3.7 x 3.3 in. (313 x 94 x 84 mm)
- Weight: 23.6 oz (670 g) without cable

Contamination Probes

continued

CSP Probes – Beta Only



SB-32™ Beta Probe

FEATURES

NUCLEAR

- Display Units: Depending on survey meter (c/s, Bq, Bq/cm² with SI CSP instrument and CPM, DPM, DPM/100cm² with American CSP instruments)
- Emitters: Beta
- Detector: Plastic scintillator of 0.25 mm thickness
 - Detection area: 32 cm² (total diameter = 70 mm, sensitive diameter = 64mm)
 - Aluminium window made of two layers of 12 µm placed on detector entrance surface, total thickness: 24 µm
 - Protection grid transparency: 89%
- Measurement Range: 0 to 10,000 c/s, 0 to 600 kcpm. Activity equivalent range depends on calibration emitter. Conversion coefficient is factory set with ⁶⁰Co.
- Dead Time: 2 µs
- Energy Range: Beta > 150 keV
- Gamma Sensitivity ¹³⁷Cs: 1.7 c/s per µGy/h (1.0 kcpm per mR/h)
- Background:
 - Ambient ≤100 nGy/h (10 µR/h): <3 c/s (<180 cpm).
 - Alpha influence (²³⁹Pu): < 1%

MECHANICAL

- Housing: Painted aluminum
- Dimensions: Length (with connector) x diameter (detector) x diameter (body): 225 x 85 x 55 mm (8.8 x 3.3 x 2.2 in.)
- Weight: 678 g (24 oz) without cable



SB-100™ Beta Probe

FEATURES

NUCLEAR

- Display Units: Depending on survey meter (c/s, Bq, Bq/cm² or CPM, DPM, DPM/100 cm²)
- Emitters: Beta
- Detector: 0.25 mm thick plastic scintillation detector adhered to 3 mm thick neutral plastic material (PMMA)
 - Detection area: 102 cm² (68 x 150 mm)
 - Removable entrance window:
 - SB-100/A: aluminized Mylar window on metallic frame, thickness: 6 µm
 - SB-100/B: aluminum window on metallic frame, thickness: 24 µm
 - Protection grid transparency: 80%
- Measurement Range: 0 to 10000 c/s, 0 to 600 kcpm. Activity equivalent range depends on calibration emitter. Conversion coefficient is factory set with ⁶⁰Co
- Dead Time: 50 µs
- Energy Range: SB-100/A: Beta > 50 keV, SB-100/B: Beta > 150 keV
- Gamma Sensitivity ¹³⁷Cs: < 25 c/s per µGy/h (15 kcpm per mR/h)
- Background:
 - Ambient ≤100 nSv/h (10 µR/h): < 4 c/s (< 24 cpm)
 - Alpha influence (²³⁹Pu): SB-100/B < 1%, SB-100/A >33%

MECHANICAL

- Housing: Painted aluminum
- Dimensions: Length (with connector) x width (detector) x height: 12.3 x 3.7 x 3.3 in. (313 x 94 x 84 mm)
- Weight: 24 oz (670 g) without cable

CSP Smart Contamination Probes



SABG-15+™ Alpha/Beta/Gamma Probe

FEATURES

NUCLEAR

- Unit to Display: Depending on survey meter (c/s, Bq, Bq/cm² with IS units version survey meter and CPM, DPM, DPM/100 cm² with US version survey meter)
- Emitters: Alpha, beta and gamma
- Detector: Geiger-Mueller with halogen quench thin mica end window 1.8 to 2.0 mg/cm²
 - Detection area: 15.5 cm²
 - Protection grid transparency: 76%
- Measurement Range: 1 to 9999 c/s, 60 to 600 000 CPM (display: 0.1 to 9999 c/s, 0.1 CPM to 600 kCPM)
- Activity equivalent range depends on calibration emitter. Conversion coefficient is factory set with ⁶⁰Co
- Gamma Sensitivity for ¹³⁷Cs: 6.4 c/s per μGy/h (3840 CPM per mR/h)
- Dead Time: Detector = 50 μs, Probe = 50 μs
- Energy: Alpha > 2.6 MeV, Beta > 30 keV, Gamma > 5 keV

MECHANICAL

- Housing: ABS polycarbonate molded
- Dimensions: Length (with connector) x diameter (detector) x diameter (body): 8.1 x 2.8 x 1.7 in. (205 x 70 x 42 mm)
- Weight: 10.9 oz (310 g) without cable



SPAB-15™ Alpha/Beta Probe

FEATURES

NUCLEAR

- Unit to Display: Depending on survey meter (c/s, Bq, Bq/cm² or CPM, DPM, DPM/100 cm²)
- Emitters: Alpha and beta
- Detector: Silicon 1700 mm² PIPS® detector
 - Detection area: 15 cm²
 - Protection grid transparency: 75%
- Measurement Range: 0 to 10 000 c/s, 0 to 600 kcpm. Activity equivalent range depends on calibration emitter. Conversion coefficients are factory set with ²³⁹Pu for alpha channel and with ⁶⁰Co for beta channel
- Dead Time: 8 μs with digital saturation at 10 000 c/s
- Energy Range: Beta > 100 keV, Alpha > 3 MeV
- Gamma Sensitivity for ¹³⁷Cs: 8 c/s per μGy/h (4800 cpm per mR/h)
- Background: Ambient ≤ 100 nSv/h (10 μR/h): Alpha < 0.01 c/s (< 0.6 cpm), Beta < 0.8 c/s (< 48 cpm)
- Cross Talk: Alpha to Beta (²³⁹Pu) < 3%, Beta to Alpha (⁹⁰Sr-⁹⁰Y) = < 0.1%

MECHANICAL

- Housing: ABS polycarbonate molded
- Dimensions: Length (with connector) x diameter (detector) x diameter (body): 6.7 x 2.6 x 1.5 in. (170 x 66 x 38 mm)
- Weight: 9.9 oz (280 g) with protective cap and without cable

Contamination Probes

continued



SAB-32™ Alpha/Beta Probe

FEATURES

NUCLEAR

- Unit to Display: Depending on survey meter (c/s, Bq, Bq/cm² with SI CSP instrument and CPM, DPM, DPM/100 cm² with American CSP instruments)
- Emitters: Alpha and beta
- Detector: ZnS(Ag) adhered to 0.25 mm thick plastic scintillation material
 - Detection area: 32 cm² (total diameter = 70 mm, sensitive diameter = 64mm)
 - Mylar window made of two layers of 3 μm placed on detector entrance surface, total thickness: 6 μm
 - Protection grid transparency: 89%
- Measurement Range: 0 to 10,000 c/s, 0 to 600 kcpm. Activity equivalent range depends on calibration emitter. Conversion coefficient is factory set with ⁶⁰Co for beta and ²³⁹Pu for alpha.
- Dead Time: 2 μs
- Energy Range: Beta > 150 keV, Alpha > 3 MeV.
- Gamma Sensitivity for ¹³⁷Cs: Beta < 10 c/s/μSv/h; Alpha < 0.005 c/s/μSv/h
- Background: Ambient ≤ 100 nSv/h (10 μR/h): Alpha < 0.01 c/s (< 0.6 cpm), Beta < 1 c/s (< 60 cpm)

MECHANICAL

- Housing: Painted aluminum
- Dimensions: Length (with connector) x diameter (detector) x diameter (body): 225 x 85 x 55 mm (8.8 x 3.3 x 2.2 in.)
- Weight: 24 oz (680 g) without cable



SAB-250™ Alpha/Beta Probe

FEATURES

NUCLEAR

- Unit to Display: Depending on survey meter - c/s, Bq, Bq/cm², cpm, dpm, dpm/100cm²
- Emitters: Alpha and beta
- Detector: ZnS(Ag) adhered to 0.25 mm thick plastic scintillation material
 - Detection area: 240 cm²
 - Removable aluminized Mylar entrance window on metallic frame, thickness: 6 μm
 - Protection grid transparency: 83%
- Measurement Range: 0 to 7 000 c/s, 0 to 420 kcpm. Activity equivalent range depends on calibration emitter. Conversion coefficient is factory set with ⁶⁰Co for beta and ²³⁹Pu for alpha.
- Dead Time: < 20 μs
- Energy Range: Beta > 150 keV, Alpha > 3 MeV.
- Gamma Sensitivity for ¹³⁷Cs: Beta < 70 c/s per μGy/h; Alpha < 0.3 c/s per μGy/h
- Background: Ambient < 100 nGy/h (10 μR/h): Alpha < 0.01 c/s (< 0.6 cpm), Beta < 35 c/s (< 600 cpm)

MECHANICAL

- Housing: stainless steel
- Dimensions: 360 x 150 x 125 mm (14.2 x 5.9 x 4.9 in)
- Weight: < 1.2 kg (2.6 lb) without cable



SAB-100™ Alpha/Beta Probe

FEATURES

NUCLEAR

- Unit to Display: Depending on survey meter (c/s, Bq, Bq/cm² or CPM, DPM, DPM/100 cm²)
- Emitters: Alpha and beta
- Detector: ZnS(Ag) adhered to 0.5 mm thick plastic scintillation material
 - Detection area: 102 cm² (68 x 150 mm)
 - Removable aluminized Mylar entrance window on metallic frame, thickness: 6 μm
 - Protection grid transparency: 80%
- Measurement Range: 0 to 10000 c/s, 0 to 600 kcpm. Activity equivalent range depends on calibration emitter. Conversion coefficients are factory set with ²³⁹Pu for alpha channel and with ⁶⁰Co for beta channel
- Dead Time: 50 μs
- Energy Range: Beta > 150 keV, Alpha > 3 MeV.
- Gamma Sensitivity for ¹³⁷Cs: < 35 c/s per μGy/h
- Background: Ambient ≤ 100 nSv/h (10 μR/h): Alpha < 0.05 c/s (< 3.0 cpm), Beta < 6.0 c/s (< 360 cpm)
 - Sunlight effect: No effect up to 80000 lux.
 - Cross Talk: Alpha to Beta (²³⁹Pu) < 15%, Beta to Alpha (⁹⁰Sr-⁹⁰Y) < 0.1%

MECHANICAL

- Housing: Painted aluminum
- Dimensions: Length (with connector) x width (detector) x height (detector): 12.3 x 3.7 x 3.3 in. (313 x 94 x 84 mm)
- Weight: 24 oz (670 g) without cable



SABG-100™ Alpha/Beta/Gamma Probe

FEATURES

NUCLEAR

- Unit to Display: Depending on survey meter (c/s, Bq, Bq/cm² or CPM, DPM, DPM/100 cm²)
- Emitters: Alpha and beta-gamma
- Detector: ZnS(Ag) adhered to 1.5 mm thick plastic scintillation material
 - Detection area: 102 cm² (68 x 150 mm)
 - Removable aluminized Mylar entrance window on metallic frame: 6 μm thick
 - Protection grid transparency: 80%
- Measurement Range: 0 to 10 000 c/s, 0 to 600 kcpm. Activity equivalent range depends on calibration emitter. Conversion coefficients are factory set with ²³⁹Pu for alpha channel and with ⁶⁰Co for beta channel
- Dead Time: 8 μs
- Energy Range: Beta >150 keV, Alpha >3 MeV, Gamma >100 keV
- Gamma Sensitivity in Dose Rate for ¹³⁷Cs: ≥65 c/s per μGy/h (39 kcpm per mR/h)
- Gamma Sensitivity in Activity: Sealed source positioned at 20 mm from the protection grid:

Radionuclide	Gamma sensitivity in c/s per kBq
¹³⁷ Cs	2.7
⁶⁰ Co	9.0
⁵⁷ Co	1.4
²⁴¹ Am	0.01

- Background: Ambient ≤ 100 nSv/h (10 μR/h): Alpha < 0.05 c/s (< 3.0 cpm), Beta < 10.0 c/s (< 600 cpm)
 - Sunlight effect: No effect up to 80 000 lux.
 - Cross Talk: Alpha to Beta (²³⁹Pu) < 15%, Beta to Alpha (⁹⁰Sr-⁹⁰Y) < 0.1%

MECHANICAL

- Housing: Painted aluminum
- Dimensions: Length (with connector) x width (detector) x height: 12.3 x 3.7 x 3.3 in. (313 x 94 x 84 mm)
- Weight: 24 oz (670 g) without cable

Contamination Probes

continued



The use of this probe with SAB-250 probe is a one Hand/ One Foot system connected to the AVIOR-2 meter

SABP-525™ Foot Alpha/Beta Probe

FEATURES

NUCLEAR

- Unit to Display: Depending on survey meter (c/s, Bq, Bq/cm² (depending on survey meter)
- Emitters: Alpha and beta
- Detector: Plastic scintillator 0.25 mm thick, covered by ZnS(Ag) for Alpha detection, mounted on a PMMA support 35 mm thick
 - Detection area: 525 cm²
 - Mylar window made of three layers of aluminized Mylar 0.4-0.45 mg/cm²
 - Protection grid transparency:
 - Internal protective thin grid 0.25 mm thick: 80 %.
 - External protective grid 3 mm thick: 91 %
- Measurement Range: 0 to 7 000 c/s, 0 to 420 kcpm. Activity equivalent range depends on calibration emitter. Conversion coefficients are factory set with ²³⁹Pu for alpha channel and with ⁶⁰Co for beta channel. for beta and for alpha.
- Dead Time: < 20 μs
- Energy Range: Alpha > 3 MeV, Beta > 150 KeV
- Gamma Sensitivity for ¹³⁷Cs:
 - Alpha: < 0.3 c/s per μGy/h,
 - Beta: < 150 c/s per μGy/h
- Background: Ambient ≤ 100 nSv/h (10 μR/h):
 - Alpha < 0.1 c/s (< 6.0 cpm); Beta < 20 c/s (< 1200 cpm))

MECHANICAL

- Housing: Painted aluminum
- Dimensions: Length x width x height: 485 x 220 x 215 mm (19 x 8.6 x 8.5 in.).
- Weight: < 10 kg (22 lb) without cable



Easy-Count unit can be used with the Colibri meter, AVIOR-2 meter and RDS-32 meter

EASY-COUNT™ Field Smear/Filter Counter

FEATURES

NUCLEAR

- Unit to Display: Depending on survey meter - CPM, DPM, DPM/100 cm², c/s, Bq_{eq}, Bq_{eq}/cm²
- Emitters: Alpha and beta
- Detector: Silicon 1700 mm² PIPS detector
 - Detection area: 17 cm²
- Measurement Range: 0 to 10 000 c/s, 0 to 600 kcpm. Activity equivalent range depends on calibration emitter. Conversion coefficients are factory set with ²³⁹Pu for Alpha channel and with ⁶⁰Co for Beta channel.
- Dead Time: 8 µs with digital saturation at 10 000 c/s
- Energy Range: Beta > 100 keV, Alpha > 3 MeV
- Gamma Sensitivity for ¹³⁷Cs: 8 c/s per µGy/h (4800 cpm per mR/h)
- Background: Ambient ≤100 nSv/h (10 µR/h): Alpha <0.01 c/s (<0.6 cpm), Beta <0.8 c/s (<48 cpm)

MECHANICAL

- Housing: aluminium
- Dimensions: 23.4 x 17,8 x 33.7 cm (9.2 x 7.0 x 13.3 in.)
- Weight: 2.1 kg (4.62 lb) without meter

Contamination Probes

continued

CSP Smart Contamination and Dose Equivalent Rate Probes

Each probe has a very specific design to match both the environmental parameters (fuel pool monitoring in water, remote dose-rate monitoring, public area monitoring) and the user protection requirement (distance from the measurement point). TTC-based probes feature Mirion's unique Time-To-Count design that offers a wide measurement range, a long detector live time and excellent measurement linearity with no fold-over effect. CSP dose-rate probes cover very low to very high dose-rates with sufficient overlap. All probes utilize energy compensated detectors and meet the latest ICRP requirements.

CONTAMINATION CSP PROBES



SX-2R™ X-Ray Probe

FEATURES

NUCLEAR

- Display Units: Depending on survey meter (c/s, Bq, Bq/cm² or CPM, DPM, DPM/100 cm²)
- Emitters: X-ray and low energy Gamma
- Detector: NaI(Tl) 1.5 in. (38 mm) dia x 3 mm
 - Detection area: 8 cm²
 - Beryllium entrance window 37 mg/cm², thickness: 0.2 mm
- Measurement Range: 0 to 10 000 c/s, 0 to 600 kcpm. Activity equivalent range depends on calibration emitter. Conversion coefficient is factory set with ¹²⁹I
- Dead Time: 50 μs
- Energy Range: 5 keV to 200 keV
- Gamma Sensitivity for ¹³⁷Cs: 160 c/s per μGy/h (96 kcpm per mR/h)
- Background: Ambient ≤100 nSv/h (10 μR/h): <12 c/s (<720 cpm)

MECHANICAL

- Housing: Painted aluminum
- Dimensions: Length (with connector) x diameter: 8.9 x 2.3 in. (225 x 59 mm)
- Weight: 21 oz (590 g) without cable



SG-1R™ Gamma Probe

FEATURES

NUCLEAR

- Unit to Display: Depending on survey meter (c/s, Sv_{eq}, Sv_{eq}/h or CPS, R, R/h)
- Emitters: Gamma and X
- Detector: NaI(Tl) scintillator 1" x 1"
- Measurement Range: 0 to 200 μSv/h (0 to 20 mR/h); 0 to 55 kc/s (0 to 3300 kcpm)
- Energy Range: 40 keV to 1.5 MeV
- Gamma Sensitivity for ¹³⁷Cs: 291 c/s per μGy/h (174.6 kcpm per mR/h)
- Dead Time: 50 μs
- Background: Ambient ≤100 nSv/h (10 μR/h): 25 c/s – 1500 CPM

MECHANICAL

- Housing: Painted aluminum
- Dimensions: Length (with connector) x diameter: 9.2 x 2.2 in. maximum (233 x 55 mm)
- Weight: 18 oz (520 g) without cable



SG-2R™ Gamma Probe

FEATURES

NUCLEAR

- Unit to Display: Depending on survey meter (c/s, Sv_{eq}, Sv_{eq}/h or CPS, R, R/h)
- Emitters: Gamma and X
- Detector: NaI(Tl) scintillator 2" x 2"
- Measurement Range: 0 to 50 μSv/h (0 to 5 mR/h); 0 to 90 kc/s (0 to 5400 kcpm)
- Energy Range: 40 keV to 1.5 MeV
- Gamma Sensitivity for ¹³⁷Cs: 1501 c/s per μGy/h (900.6 kcpm per mR/h)
- Dead Time: 50 μs
- Background: Ambient ≤100 nSv/h (10 μR/h): 120 c/s – 7200 CPM

MECHANICAL

- Housing: Painted aluminum
- Dimensions: Length (with connector) x diameter: 10.4 x 2.6 in. (263 x 66 mm maximum)
- Weight: 35 oz (1000 g) without cable

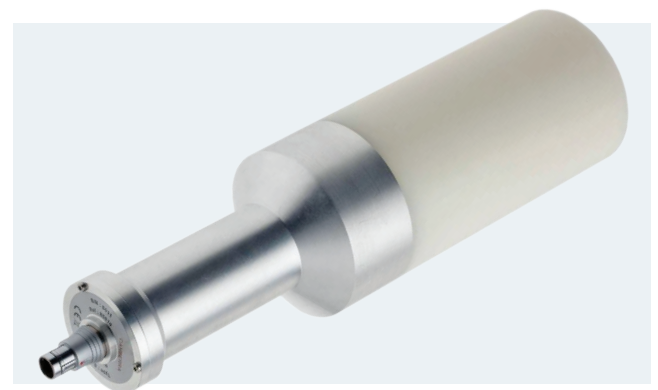

SN-S™ Neutron Search Probe

FEATURES

NUCLEAR

- Display Units: CPS
- Display Range: 0.0 cps to 20 Kcps
- Emitters: Neutron
- Detector: PEHD Moderated ³He detector
- MDA: ²⁵²Cf neutron source of 20 000 n/s at 25 cm is detected in 2 s 950 times out of 1000, with 0.03 cps background
- Measurement Range: 0 cps to 20 Kcps
- Energy Range: 0.025 eV to 4 MeV
- Sensitivity:
 - 1.6 cps per μSv/h (²⁵²Cf). i.e. 2.1 c/s per n.cm⁻².s⁻¹ (²⁵²Cf at one meter distance from the source)
 - 2.3 cps per μSv/h (²⁵²Cf). i.e. 2.7 cps per n.cm⁻².s⁻¹ (²⁵²Cf at two meters distance from the source)

MECHANICAL

- Probe Housing: Aluminium and PEHD
- Length: 13.54 in. (340 mm)
- Diameter: 0.98 in. (85 mm)
- Weight: 2.93 lb (1.33 kg)

Contamination Probes

continued

DOSE EQUIVALENT RATE CSP PROBES



STTC™ Wide Range Gamma Probe

FEATURES

NUCLEAR

- Display Units: Sv/h, Sv or rem, rem/h depending on meter connected; H*(10) ambient gamma dose equivalent rate (according to ICRP60)
- Emitters: Gamma
- Detector: Energy Compensated Geiger Mueller
- Sensitivity: 0.74 c/s for $\mu\text{Sv/h}$ (^{137}Cs)
- Measurement Range: 0.1 $\mu\text{Sv/h}$ to 10 Sv/h (10 $\mu\text{rem/h}$ to 1000 rem/h)
- IEC Approved Range: 0.7 $\mu\text{Sv/h}$ to 10 Sv/h (70 $\mu\text{rem/h}$ to 1000 rem/h)
- IEC Energy Range: Gamma 36 keV to 1.5 MeV
- Background: Ambient < 0.1 $\mu\text{Gy/h}$ (10 $\mu\text{R/h}$), 0.10 c/s
- Maximum Integrated Dose: Approximately 500 Sv

MECHANICAL

- Housing: Aluminum
- Dimensions (without connector): 6.38 in. x 1.77 in. (162 x 45 mm) (L x D)
- Weight (STTC): 0.3 lb (130 g), without cable



SVLD™ Very Low Dose Rate Probe

FEATURES

NUCLEAR

- Display Units: Sv/h, Sv or rem/h, rem depending on meter connected, H*(10) ambient gamma dose rate equivalent according to ICRP60
- Emitters: Gamma
- Detector: Energy compensated CsI(Tl) scintillator
- Sensitivity: 70 c/s per $\mu\text{Sv/h}$ (^{137}Cs)
- Measurement Range: 10 nSv/h to 1 mSv/h (1 $\mu\text{rem/h}$ to 100 mrem/h)
- IEC Approved Range: 100 nSv/h to 1 mSv/h (10 $\mu\text{rem/h}$ to 100 mrem/h)
- IEC Energy Range: Within $\pm 40\%$ for Gamma from 59 keV to 1.5 MeV
- Background: Ambient ≤ 100 nGy/h (10 $\mu\text{R/h}$): < 5 c/s (< 300 cpm), typical = 3 c/s

MECHANICAL

- Housing: Machined Delrin
- Dimensions: Length (with connector) x width x height: 4.11 x 3.14 x 1 in. (104.4 x 80 x 26 mm)
- Connector: Lockable waterproof Fisher type
- Weight: 6.24 oz (177 g) without cable



SN-D-2™ Neutron Dose Probe

FEATURES

NUCLEAR

- Display Units: Sv/h, Sv, rem/h, rem
- Emitters: Neutron
- Detector: ^3He filled tube 16NH8NC (8 atm) with 1 mm Cadmium wrap and 200 mm PEHD moderating sphere
- Sensitivity: 0.3 c/s per $\mu\text{Sv/h}$ (Cf-252)
- Measurement Range: 10 nSv/h to 1 mSv/h (1 $\mu\text{rem/h}$ to 100 mrem/h)
- Energy Range: 0.025 eV to 15 MeV within IEC61005-2014 tolerances
- Dead Time: < 8 μs
- Gamma Sensitivity: Gamma Rejection > 103
- Background: Ambient \leq 100 nGy/h (10 $\mu\text{R/h}$): < 0.05 c/s (< 3.0 cpm)

MECHANICAL

- Housing: Painted aluminium
- Dimensions: Sphere dia x height (without survey meter): 200 x 330 mm (7.9 x 13 in)
- Weight: < 5.9 kg (12.6 lb) without meter



Tele-STTC-2™ Wide Range Gamma Telescopic Probe with RDS-32 meter

FEATURES

NUCLEAR

- Nuclear Units to Display: sv/h, sv or rem, rem/h depending on survey meter connected
- Emitters: Gamma
- Detector: Energy compensated Geiger Mueller
- Energy Range: Gamma 36 keV to 1.5 MeV
- Sensitivity: 0.74 c/s for $\mu\text{sv/h}$ (^{137}Cs).
- Measurement Range: 0.1 $\mu\text{sv/h}$ to 10 sv/h (10 $\mu\text{rem/h}$ to 1000 rem/h)

MECHANICAL

- Housing: Aluminium
- Pole: Carbon Fiber and stainless steel (meter stand)
- Dimensions:
 - Closed Pole: 1080 mm (3.54 ft)
 - Opened Pole: 4090 mm (13.4 ft)
- Weight: 1.7 kg (3.75 lb) without meter
- Storage: Storage case for Tele-STTC-2 is included

Contamination and Clearance

OBJECT MONITORS

A nuclear facility is not unlike any other industrial environment, where routine work takes place on a regular basis, including tools, paperwork, and computers coming in and out of a Radiologically Controlled Area (RCA). The screening process often involves the painstaking task of checking the object with a handheld survey instrument, ultimately causing the worker delays exiting the area. An automated tool and object monitor can expedite this process by providing a fast, accurate screening, allowing those instruments that do not test positive to bypass the more labor-intensive frisking process with survey meters.

PERSONNEL MONITORS

Ensuring that personnel exiting an RCA are clear of any radioactive contamination is one of the primary goals of any contamination monitoring program. Due to the sheer number of workers coming and going, personnel movement is one of the easiest means to spread contamination from inside a controlled area to the general public. Contamination screening is also a key step in ensuring that workers' radiological exposure and possible health effects are kept to a minimum. While detection accuracy is a key concern, rapid worker throughput is also critical to avoid excessive wait times and the temptation for workers to skip steps just to get home sooner.



Argos
Whole Body
Contamination
Monitors

WASTE MONITORS

Waste monitors provide a method of quickly processing large containers or items and identifying any radioactive material that may be present before off-site release. Process knowledge or laboratory analysis of the isotopic inventory of a particular waste stream can be utilized to provide scaling factors for pure alpha and beta emitting nuclides which cannot be measured directly.

VEHICLE MONITORS

A nuclear facility is obligated to ensure that there is no uncontrolled release of radioactive material to the general public, including radiological contamination due to vehicles and cargo containers that pass into and out of the plant on a regular basis. Any vehicles exiting the Protected Area need to be quickly and effectively screened for the presence of radioactive materials or contamination before leaving the facility.

FastTrack-Vehicle
(FTV) monitors



Personnel Monitors

Argos™ Family Whole Body Surface Contamination Monitors

Argos monitors are available in gas-flow Alpha/Beta; gasless Beta, Alpha/Beta; or Beta/Gamma versions as part of our TPS family and with 18 or 25 detectors. The detectors may be upgraded (gas to TPS or TPS to gas) in the Argos-3/5 systems manufactured since February 2008.

COMMON FEATURES

- Contoured monitor design reduces body-to-detector distance to one inch on the average person
- Minimal gaps between detectors for smaller dead zones
- Virtual detector sum zones for enhanced coverage
- Common software platform simplifies training and support
- Efficient, front access, space-saving design minimizes overall clearance requirements and simplifies maintenance
- Built-in computer with Windows embedded operating system and LAN/USB capability for easy system management
- Solid state drive for improved reliability
- Compliant with IEC61098 Standard requirements

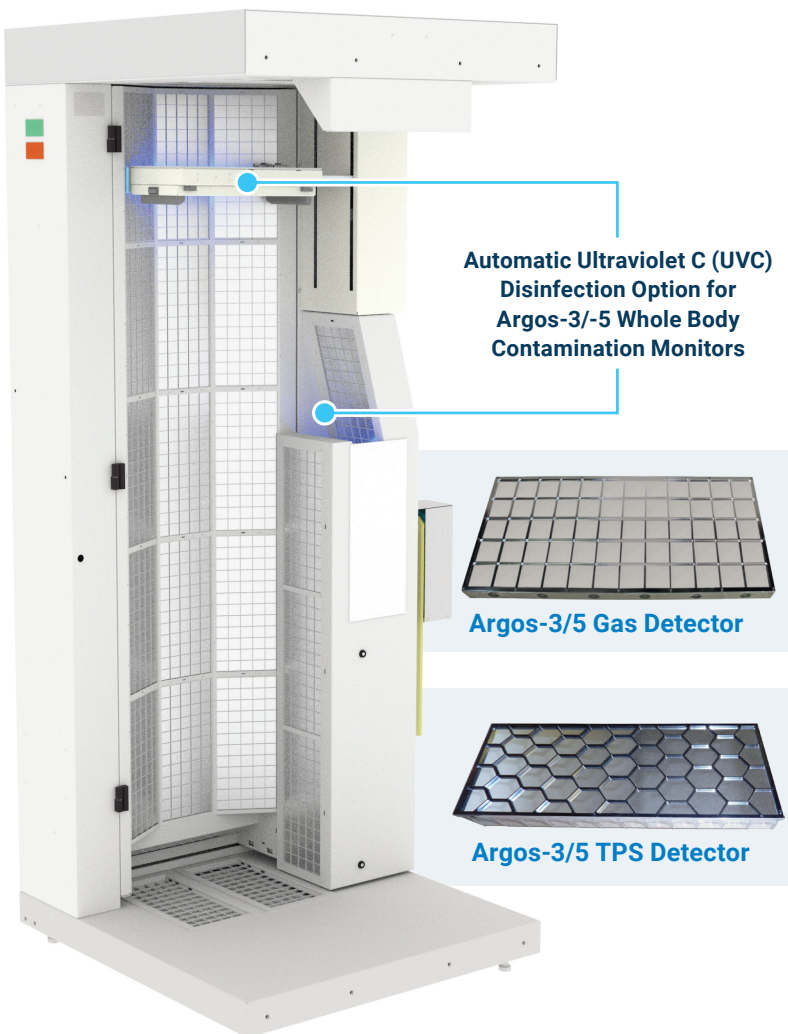

Gas-Flow versus TPS

Gas-Flow

Triple Zone detector



GAS-FLOW SYSTEM BENEFITS

- The best efficiency and Minimum Detectable Activity for the shortest count times
- Exceptional detection capability resulting from patented* triple zone detector design
- A variety of gas mixtures can be used, including: P-5, P-7.5, P-10 and Ar/CO₂
- Uniform response across detector face

* Patent US 7,470,913 B1 High Efficiency and High Homogeneity Large-Area Gas-Filled Detectors

TPS

Single Zone detector

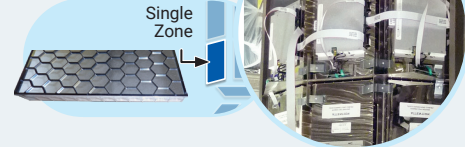

TPS SYSTEM BENEFITS

- Gas-free - no cost or worry associated with handling gas
- α/β , β/γ or β monitoring with discrimination between radiation types
- Reduced count time even in high γ background environment compared to other gasless detectors

Argos™-5 Monitor

Argos-5 Configuration

25 Detectors



Argos™-5AB Gas-Flow
Whole Body Contamination
Monitors for α/β Detection



Argos™-5PB Gasless
Whole Body Contamination
Monitors for β Detection



Argos™-5PBG Gasless
Whole Body Contamination
Monitors for β/γ Detection



Argos™-5PAB Gasless
Whole Body Contamination
Monitors for α/β Detection

GAS-FLOW SYSTEM MODEL

- **7061780** Argos-5AB, 2-Step Whole Body Monitor
 - Twenty-five (25) triple-zone Model LFP-579, 579 cm², low flow proportional detectors
 - Dual channels for simultaneous and independent alpha and beta counting and alarm levels

GASLESS (TPS FAMILY) MODELS

- **818001** Argos-5PB, 2-Step Whole Body Monitor
 - Twenty-five (25) Model TPS-B-579 TPS Plastic Scintillator detectors, 579 cm²
- **Argos-5PBG***, 2-Step Whole Body Monitor
 - Twenty-five (25) Model TPS-BG-579 TPS Plastic Scintillator detectors, 579 cm²
- **Argos-5PAB**, 2-Step Whole Body Monitor
 - Twenty-five (25) Model TPS-AB-579 TPS Plastic Scintillator detectors, 579 cm²

* – Requires CURTAINPB Front Curtain Lead Kit

Argos™-3 Monitor

Argos-3 Configuration

18 Detectors



Argos™-3AB Gas-Flow
Whole Body Contamination
Monitors for α/β Detection



Argos™-3PB Gasless
Whole Body Contamination
Monitors for β Detection



Argos™-3PBG Gasless
Whole Body Contamination
Monitors for β/γ Detection



Argos™-3PAB Gasless
Whole Body Contamination
Monitors for α/β Detection

GAS-FLOW SYSTEM MODEL

- **7062322** Argos-3AB, 2-Step Whole Body Monitor
 - Eighteen (18) triple-zone Model LFP-579, 579 cm², low flow proportional detectors
 - Dual channels for simultaneous and independent alpha and beta counting and alarm levels

GASLESS (TPS FAMILY) MODELS

- **7062324** Argos-3PB, 2-Step Whole Body Monitor
 - Eighteen (18) Model TPS-B-579 Thin Plastic Scintillator detectors, 579 cm²
- **Argos-3PBG***, 2-Step Whole Body Monitor
 - Eighteen (18) Model TPS-BG-579 Thin Plastic Scintillator detectors, 579 cm²
- **Argos-3PAB**, 2-Step Whole Body Monitor
 - Eighteen (18) Model TPS-AB-579 Thin Plastic Scintillator detectors, 579 cm²

Personnel Monitors

continued

**Argos™-3 Compact Body Contamination Monitor**

The Argos-3 Compact features the most compact dimensions of all Mirion Whole Body Contamination Monitors and is therefore well suitable for locations with size constraints. It is ideal for reliable contamination control at checkpoints inside a radiologically controlled area (RCA), as a pre-monitor or at the exit of the controlled area. When equipped with optional casters (SCN 7063138) the Argos-3 Compact can be easily moved to temporary checkpoints.

AVAILABLE IN FOUR VERSIONS

- **Argos-3AB Compact** is equipped with our most advanced LFP-579 gas flow detectors optimized for the best possible alpha and beta response.
- **Argos-3PB Compact** is equipped with TPS-B-579 thin plastic scintillation detectors for measurement of beta contamination with no need for a gas-supply.
- **Argos-3PAB Compact** is equipped with TPS-AB-579 thin plastic scintillation detectors with state-of-the-art gas-free alpha and beta detection capability (with discrimination).
- **Argos-3PBG Compact** is equipped with TPS-BG-579 plastic scintillation detectors featuring a unique gas-free beta and gamma detection capability (with discrimination).

The 15 detectors have been arranged in a configuration that minimizes dead space and provides optimal contour geometry and coverage for the occupant.

The Argos-3 Compact features by default 15 detectors (compared to 18 detectors in Argos-3 unit), which provides the best compromise for cost-effective whole body coverage. The Argos-3 Compact can be easily upgraded in the field with additional detectors (up to 24 detectors in total). All Argos monitors use a sophisticated “fast following” background trending and release-limit algorithm to provide the best possible performance in a stable or varying radiation field.

FEATURES**OPERATIONAL**

- 8.4 in. touch screen display
- Featuring the identical comprehensive monitor software platform used on the other Argos-3/5, Sirius™-5, Cronos®-1/4/11 and GEM™-5 contamination monitors

OPTIONS

- ID readers
- Additional detectors (up to a total of 24)
- Frisker
- Local database support
- Top of shoe detector (gamma)
- Keyboard Options

MECHANICAL

- Dimensions:
 - Height: 86 in. (218.5 mm)
 - Width: 30.8 in. (78.2 mm)
 - Depth: 33.3 in. (84.5 mm)
- Weight: approx. 400-485 lb (180-220 kg) depending on configuration
- Casters/wheels available for easy relocation (optional)

GEM™-5 Gamma Exit Monitor

Mirion's highly sensitive GEM-5 gamma exit monitor provides power plants and nuclear facilities the very latest gamma detection capability to monitor pedestrians leaving areas of potential radioactive contamination.

Operation of the monitor is straightforward and reliability is assured with both audible and visual aids to support monitoring activities. The easy to view color LCD screen provides visual cues and readily displays contaminated areas. Additionally, users are guided through the monitor with a voice annunciator, which provides clear voice prompts necessary for dependable unassisted operation during normal conditions. Access to the installed computer is through a single convenient panel on the front of the monitor. The computer includes built-in USB and LAN ports, and is located inside a lockable door. The GEM-5 monitor is rugged, reliable and extremely easy to use.

FEATURES

DIMENSIONS

- Cabinet:
 - Exterior: 88.4 x 35 x 30 in. (224.8 x 88.9 x 76.2 cm) (H x W x D)
 - Portal Opening: 80.9 x 24 x 30 in. (205.4 x 61.0 x 76.2 cm) (H x W x D)
- Model Weight:
 - Weight Without Lead Installed: 995 lb (452.5 kg)
 - Weight With One Layer Of Side Detector Lead Shielding Installed: 2145 lb (975 kg)
 - Weight With Two Layers Of Side Detector Lead Shielding Installed: 3295 lb (1497.5 kg)

ENVIRONMENTAL

- Temperature Range:
 - Operating Temperature (meets IEC61098): 0 to 40 °C (32 to 104 °F)
 - Storage: 0 to 50 °C (32 to 122 °F)
- Relative Humidity:
 - Operating Temperature (per IEC61098): ≤85% non-condensing at 35 °C (95 °F) maximum
 - Storage: ≤95% non-condensing
- Power Requirements:
 - 220 V ac/50 Hz/ 1.0 A or 110 V ac/60 Hz/2.0 A mains ~10 ft (3 m) IEC standard cable (supplied; specify voltage and any special cable requirements on order; contact local Mirion affiliate for further information)

POWER CONSUMPTION

- Standard: 110 VA and With Door /Barrier Option: 200 VA (If installed)

CERTIFICATIONS

- IEC 61098 compliant
- ISO 11929:2010 compliant



Personnel Monitors

continued



HandFoot-Fibre™ XL Hand, Foot, Clothing Monitor (Gas-less)

The HandFoot-Fibre XL unit is used in circumstances which do not require a full body monitor. It is well-suited for mobile contamination screening inside controlled areas or in temporary controlled areas. The monitor is based on state-of-the-art Mirion BetaFibre™ detectors which feature an outstanding measurement sensitivity and uniformity – for a fast and reliable measurement process even in conditions with high, fluctuating background. A medical version that has a higher sensitivity to lower energy isotopes is also available.

FEATURES

NUCLEAR

- Detectors: Eight scintillation fiber
- Short measurement time

OPERATIONAL

- Display: Touch screen for configuration and data display
- Audio and visual alarms

MECHANICAL

- Housing: Wheels for easy transport
- Dimensions:
 - Height: 65.4 in. (1660 mm)
 - Width: 18.2 in. (478 mm)
 - Depth: 29.5 in. (750 mm)
- Weight: 125.7 lb (57 kg)
- 100% gas-free
- Detachable probe, e.g., for monitoring of clothes



HandFoot-Fibre™ XL A+ Hand, Foot, Clothing with Alpha Monitor

The HandFoot-Fibre XL A+ unit is the next evolutionary step of the proven HFF XL. Utilizing slightly different detectors than the original fiber detectors. Mirion has now made it possible to not only detect beta but alpha radiation in a gasless monitor while still providing short count times. This monitor is ideal for those locations where alpha detection is required but use of a gas bottle is not an option.

FEATURES

NUCLEAR

- Detectors: Eight scintillation fiber
- Short measurement times
- Alpha / Beta discrimination

OPERATIONAL

- Display: Touch screen for configuration and data display
- Audio and visual alarms

MECHANICAL

- Housing: Wheels for easy transport
- Dimensions:
 - Height: 65.4 in. (1660 mm)
 - Width: 18.2 in. (478 mm)
 - Depth: 29.5 in. (750 mm)
- Weight: 125.7 lb (57 kg)
- 100% gas-free
- Detachable probe, e.g., for monitoring of clothes

Sirius™-5 Hand, Cuff and Foot Surface Contamination Monitor

Sirius-5 monitor provides thorough and reliable detection of external contamination on the hands and feet of personnel working in nuclear environments. Depending on your monitoring needs, Sirius monitors are designed to use either plastic scintillator (TPS) gasless detectors or patented* gas flow proportional detectors (LFP-579). The Sirius-5 Hand, Cuff and Foot monitor meets the need for a robust, industrial-strength contamination control product. It is designed for the high-throughput, demanding applications found in the nuclear industry – nuclear power plants, fuel cycle facilities, nuclear waste facilities and D&D operations.

α β Sirius-5AB hand/cuff/foot monitor for alpha/beta contamination:

- Six (6) large area low flow gas proportional LFP-579 detectors
- 1 step process for hands

β Sirius-5PB hand/cuff/foot monitor for beta contamination:

- Six (6) large area gasless TPS detectors
- 1 step process for hands

β γ Sirius-5PBG hand/cuff/foot monitor for beta/gamma contamination:

- Six (6) large area gasless TPS detectors
- 1 step process for hands

α β Sirius-5PAB hand/cuff/foot monitor for alpha/beta contamination:

- Six (6) large area gasless TPS detectors
- 1 step process for hands



FEATURES

MECHANICAL

- Cabinet:
 - Steel with rugged powder coat finish for column and top, stainless steel base and foot pan cover provide for ease of decontamination and minimum maintenance
 - Dimensions for any of the Sirius-5 models is approximately: 33.5 x 70.6 x 36.2 in. (78.0 x 179.3 x 91.9 cm) (W x H x D)
 - Approximate weights are (with no options installed)
- Model Weight:
 - Sirius-5AB 275.0 lb (125.0 kg)
 - Sirius-5PB /PAB/PBG 298.8 lb (135.8 kg)

* Patent US 7,470,913 B1 High Efficiency and High Homogeneity Large-Area Gas-Filled Detectors

ENVIRONMENTAL

- Temperature Range:
 - Operating Temperature (meets IEC 61098): 0-40 °C (32-104 °F)
 - Storage: 0-50 °C (32-122 °F)
- Relative Humidity:
 - Operating (per IEC 61098): ≤85% non-condensing at 35 °C (95 °F) maximum
 - Storage: ≤95% non-condensing
- Power Requirements:
 - 220 V ac/50 Hz/1.0 A or 110 V ac/60 Hz/2.0 A mains ~10 ft (3 m). IEC standard cable (supplied; other cables are available; specify special cable requirements; contact local Mirion affiliate) for further information

POWER CONSUMPTION

- 110 VA

CERTIFICATIONS

- IEC 61098 compliant
- ISO 11929:2010 compliant

Object Monitors

Cronos® Gamma Object/Tool Contamination Monitors

The Cronos-1PBG Beta/Gamma Object/Tool Monitor is an extremely sensitive instrument to detect beta and gamma emitting radioactive contamination on small objects such as notebooks, keys, tools, hard hats, and other items which can be placed in the counting chamber. Short count times and high efficiency make the Cronos-1PBG monitor, the ideal tool for the implementation of the “Empty Pocket” policy in your facility.



43 LITERS

Cronos®-1PBG Beta/Gamma Object/Tool Monitor

The Cronos Gamma Object / Tool Monitors are extremely sensitive instruments used to detect radioactivity from small articles such as notebooks, keys, tools, hard hats, and other miscellaneous objects to detecting gamma radiation in/on articles such as waste bags, tools, briefcases, hard hats, and other miscellaneous objects. Measurements which ensure that objects have no detectable radioactivity can result in significant cost savings in waste processing and/or storage.

FEATURES

NUCLEAR

- Twelve 14.6 x 6.7 x 2.3 in. (37.2 x 17.0 x 5.8 cm) thin plastic scintillation (TPS-BG-579) detectors with built-in photomultiplier tubes.
- Total detector volume 23.4 L (0.83 cu.ft)

OPERATIONAL

- Display Screen: 10.4 in. (~264 mm) touch screen LCD display integrated in top of unit (second display kit optionally available for exit side)

ELECTRICAL

- 220 V ac / 50 Hz / 1.0 A or 110 V AC / 60 Hz / 2.0 A mains
- Maximum power consumption is 95 VA
- ~10 ft (3 m) IEC standard power cable supplied

MECHANICAL

- Unit with No Lead: 600 lb (272 kg)





Cronos-1 Gamma Object/Tool Monitor

Cronos-4 Gamma Object/Tool Monitor

Cronos-11 Gamma Object/Tool Monitor

43 LITERS

129 LITERS

345 LITERS

FEATURES

		Cronos-1 Monitor		Cronos-4 Monitor	Cronos-11 Monitor
Radiological:	Calculated count times for MDA=83 Bq (5000 dpm) 80 nSv/h background, 1" lead shielding, $\alpha = 0.15\%$ and $1-\beta = 97.5\%$ confidence intervals.	<u>6 Detector Configuration</u>	<u>4 Detector Configuration</u>	<u>6 Detector Configuration</u>	<u>6 Detector Configuration</u>
Time to reach MDA		For ¹³⁷ Cs: 24 seconds For ⁶⁰ Co: 6 seconds	For ¹³⁷ Cs: 35 seconds For ⁶⁰ Co: 9 seconds	For ¹³⁷ Cs: 48 seconds For ⁶⁰ Co: 10 seconds	For ¹³⁷ Cs: 130 seconds For ⁶⁰ Co: 22 seconds
Detectors		<ul style="list-style-type: none"> For doors and main unit: six 38.7 x 33.2 x 5.1 cm (15 x 13 x 2 in.) plastic scintillators with built-in photomultiplier tubes. Detector volume for main unit detectors (four total) 25.5 L (0.90 cu. ft.). Detector volume for main unit and Optional door detectors (six total) 38.2 L (1.4 cu. ft.). 	<ul style="list-style-type: none"> For doors and main unit: six 45.7 x 45.7 x 5.1 cm (18 x 18 x 2 in.) plastic scintillators with built-in photomultiplier tubes. 65.1 L (2.3 cu. ft) total detector volume. 	<ul style="list-style-type: none"> For doors: two 61 x 61 x 5.1 cm (24 x 24 x 2 in.) plastic scintillators with built-in photomultiplier tubes. For main unit: four 61 x 74.9 x 5.1 cm (24 x 29.5 x 2 in.), plastic scintillators with built-in photomultiplier tubes. 130.5 L (4.6 cu. ft) total detector volume. 	
Mechanical:					
Internal Dimensions	Width x Depth x Height	34.1 cm (13.4 in.) x 36.5 cm (14.4 in.) x 34.5 cm (13.6 in.)		46.5 cm (18.3 in.) x 57.9 cm (22.8 in.) x 47.8 cm (18.8 in.)	63.5 cm (25.0 in.) x 87.2 cm (34.3 in.) x 62.4 cm (24.6 in.)
	Internal Volume	~42.9 L (1.5 cu. ft)		~128.7 L (4.5 cu. ft)	~345.5L (12.2 cu. ft)
	Overall Width	60.0 cm (23.6 in.)		73.2 cm (28.8 in.)	88.4 cm (34.8 in.)
	Overall Depth	73.1 cm (28.8 in.) for body and door handles		95.2 cm (37.5 in.) for body and door handles	124.4 cm (49.0 in.) for body and door handles
	Overall Height (Flush with bottom of casters or flush with bottom of the leveling feet)	<u>With Standard Leveling Feet</u> 96.3 cm (37.9 in.) <u>With Optional Casters</u> 100.4 cm (39.5 in.)		129.1 cm (50.8 in.)	145.7 cm (57.4 in.)
Weight	Door Thickness	7.0 cm (2.7 in.)		7.0 cm (2.7 in.)	7.0 cm (2.7 in.)
	Unit with No Lead	260 kg (573 lb)		445 kg (981 lb)	563 kg (1241 lb)
	Lead (1 layer)	416 kg (917 lb)		751 kg (1656 lb)	1264 kg (2787 lb)
	Lead (2 layers)	832 kg (1834 lb)		1503 kg (3314 lb)	2529 kg (5575 lb)
	Total (with 1 layer of lead)	683 kg (1506 lb)		1207 kg (2661 lb)	1841 kg (4059 lb)
Total (with 2 layers of lead)	1099 kg (2423 lb)		1958 kg (4317 lb)	3105 kg (6845 lb)	
Power Requirements:	220 V ac/50 Hz/1 Amp or 110 V ac/60 Hz/2 Amp mains 3 m (~10 ft) IEC standard cable (supplied; specify and special cable requirements on order).				
Certification:	IEC 61098 compliant and ISO 11929:2010 compliant.				
Environmental:					
Temperature	Operating temperature range 0 to +45 °C (+32 to +113 °F).				
Humidity	85% non-condensing.				



Waste Monitors



NEW

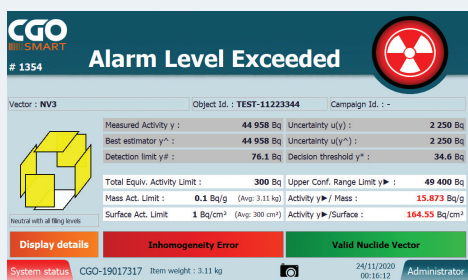

113.4 LITERS

CGO-Smart™ LNC Large Items Free Release Monitor

The CGO-Smart LNC is a universal contamination monitor for clearance and free release measurements in a single device. This highly sensitive monitor has been designed for contamination measurements of average sized items like tool boxes, bags and waste drums. This new monitor is based on the industry proven Smart™ detection technology: spectrometry using plastic scintillation detectors and energy analysis.

FEATURES

NUCLEAR

Six large-volume plastic scintillation detectors – total active volume: 113.4 liters

- 8 spectrometry channels, 256 channels each

OPERATIONAL

- Double / single doors operation
- Preconfigurable items like drums, bags, clothes, toolboxes handling background- and self-absorption compensation
- Item detection by camera or scale
- Visual and audible alarm
- Data export on USB or network - Interface to waste management system prepared

ELECTRICAL

- Operating voltage: 110-230 V, 50-60 Hz
- Operating current: 380 mA

MECHANICAL

- External dimensions: 84.0 x 89.2 x 155.0 cm³ (HxWxD)
- Dimensions of measurement chamber: 60.8 x 60.1 x 84 cm³ (HxWxD) or 307 liters
- Maximum object weight: 150 kg
- Two LCD color 10" touch screens



440 LITERS

RTM661/440™ Large Object Monitor

The RTM661/440 monitor is designed for the reliable release measurement of various objects such as tools, waste bags or briefcases. Its fast, integral gamma measurement is based on the use of gamma plastic scintillation detectors in line with modern PC-based counting electronics. The system is based on an industrial personal computer.

FEATURES

NUCLEAR

- Detector: Six large area scintillation

OPERATIONAL

- Display: 17 in. LCD
- Embedded industrial PC (fanless)
- Network ready

ELECTRICAL

- 110 to 230 V operation

MECHANICAL

- Housing:
 - Single or dual door operation
 - Separate electronic housing
- Dimensions:
 - Outside: 39.6 x 43 x 60.7 in. (1005 x 1090 x 1542 mm)
 - Chamber: 15.5 ft³ (440 L)
- Weight Scale: 330.7 lb (150 kg) max.
- Barcode scanner
- Label printer

RTM640C™ Clearance Monitor

The RTM662-460C is an advanced clearance monitor for large objects. It consists of a measurement chamber with motor-operated swing doors and automatic chain conveyor

system. The measurement objects are weighed by integrated scales and checked for gamma radiation by 6 state-of-the-art plastic scintillation detectors with spectroscopic read-out.

FEATURES

NUCLEAR

- 6 large-volume plastic scintillation detectors – total active volume: 113,4 litres,
- Spectrometric read-out, 256 channels, Energy threshold: 80 keV,
- Measurable activity range: 10 Bq to 1 000 000 Bq.

OPERATIONAL

- Single door with chain conveyor, motorized operation with PLC
- Up to 2 still cameras, triggered by position sensors

MECHANICAL

- Chamber: 70 x 70 x 95 cm³ (LxWxH), 460 liters,
- External dimensions: 115 x 158 x 235 cm³ (LxWxH),
- Conveyor: length 250 cm, max. object diameter 63 cm,
- Built-in weight scale, maximum 500 kg, 0.1 kg resolution,
- 50 to 75mm lead shielding, in-field mounting possible from the outside, transportable by crane or forklift with shielding installed,
- Total weight with Shielding: 4739,9 lb (2150 kg)



RTM644Inc™ Large Clearance Monitor

The RTM644-Smart is the most advanced clearance monitor and key monitoring equipment for every major clearance campaign. It consists of a measurement chamber with motor-operated swing doors and automatic chain conveyor system. The measurement objects are weighed by integrated scales and checked for gamma radiation by 24 state-of-the-art plastic scintillation detectors with spectroscopic read-out.

FEATURES

NUCLEAR

- 24 large-volume plastic scintillation detectors – total active volume: 372 litres
- Spectrometric read-out, with 256 channels,
- Lower Energy threshold: 80 keV,
- Measurable activity range: 10 Bq to 1 000 000 Bq.

OPERATIONAL

- Single door with chain conveyor, motorized operation with PLC,
- Up to 2 still cameras, triggered by position sensors,

- Automatic object loading, integrated in measurement

MECHANICAL

- Chamber: 138 x 112 x 121 cm³ (LxWxH), 1870 liters,
- Ext. chassis dimensions: 191 x 186 x 229 cm³ (LxWxH),
- Conveyor: default. length 300 cm
- 50 or 75mm lead shielding, 6 faces, transportable by crane with the shielding installed,
- Total weight with Shielding: 50mm: 12200,4 lb (5534 kg) 75mm: 16261,3 lb (7376 kg)



Waste Monitors

continued



RTM750™ Laundry and Small-Items Conveyor Monitor

The **RTM750 Conveyor Monitor** is a versatile contamination monitor capable of measuring material from clothing to scaffolding, and everything in between. With different detector types available, along with other options this monitor is designed to meet a multitude of applications.

FEATURES

NUCLEAR

- Detector:
 - Beta plastic
 - Gas proportional
 - Gamma scintillation
- High sensitivity

OPERATIONAL

- Display: Large LCD (touch screen optional)
- Automatic speed control
- Automatic background subtraction

MECHANICAL

- Housing: Optional cross conveyor for sorting
- Dimensions: 6.6 - 11.2 ft x 35.4 - 55.1 in. x 0.8 - 7.1 in. (2 - 3.4 m x 900 - 1400 mm x 20 - 180 mm)

Other Versions:

- RTM750BP (Gasless)
- RTM750G (Gamma)
- RTM750BG (Beta Gamma)
- RTM750BPG (Beta Gamma Gasless)
- RTM750B (Beta, P10)

Vehicle Monitors

FastTrack-Vehicle™ Vehicle Monitor

The FastTrack-Vehicle unit is a unique monitor for the screening of trucks and vehicles. It combines the FastTrack algorithm with large area, highly sensitive GammaFibre detectors. Through the use of specially developed filtering programs, the possibility of false alarms is reduced to almost zero making it the ideal choice for any location trying to screen trucks and vehicles.

FEATURES

NUCLEAR

- Detector: Six large volume gamma fibre detectors
- MDA: 70 kBq, Co-60 (distance of cabinets 4 m, speed up to 20 km/h)

MECHANICAL

- Detector volume of 1.4 ft³ (40 L)
- Modular design for ease of installation
- Remote operator console

OPERATIONAL

- Display: Touch screen operation
- Visual: Traffic light for vehicle control
- Infrared sensors for vehicle presence
- Camera system for vehicle and/or container identification
- Networkable



FastTrack-Vehicle™ XL Large Vehicle Monitor

The FastTrack-Vehicle XL monitor delivers a robust performance. Under similar circumstances a conventional gamma monitor would produce a false alarm, or even worse go into genuine alarm without actually being able to locate the vehicle or object carrying a source. The monitor combines the FastTrack technology with highly sensitive GammaFibre detectors and low energy response, making the FastTrack-Vehicle XL system a reliable partner for monitoring truckloads of vehicles in a very short time.

FEATURES

NUCLEAR

- Detectors: 2 x 6 GammaFibre
- Energy Range: 30 keV - 3 MeV
- MDA: 40 kBq, Co-60 (distance of cabinets 4 m, speed up to 20 km/h)
- Lead Shielding: 0.6 in. (15 mm)
- Optional neutron detection

MECHANICAL

- Dimensions: 96.6 x 99.8 x 10.3 in. (2453 x 2535 x 262 mm)
- Weight: 2 x 1146.4 lb (520 kg)
- False alarm prevention
- Automatic background subtraction for heavy loaded trucks also in high background
- Total Active Monitor Volume: 3.4 ft³ (96 L)



Portal Monitors



SPIR-Ident™ Portals Spectroscopic Radiation Portal Monitors (SRPM)

The SPIR-Ident Portals are spectroscopic radiation portal monitors (SRPM) with no false alarm and no nuisance alarm (medical, natural sources) thanks to the "Detection by Identification" concept. The portal will alarm only for real threats, and can provide distinct "Tolerated alarms" for medical/natural (NORM) sources. It's ideal for the security of nuclear facilities.

TWO MODELS AVAILABLE

- The Pedestrian version stands on the floor and is ideally sized for monitoring pedestrians and small vehicles.
- The Module portal is a modular version to integrate on poles, walls or existing portal frames. It is suitable for all applications: discreetly monitoring pedestrians or inspecting luggage, mail, parcels, large vehicles, trucks, trains and cargo.

FEATURES

- Highly sensitive Gamma (2 or 4 L NaI) and Neutron (BZnS) detection
- Pass-by occupancy sensor
- Audible and Visual Alert Indicators
- Network connectivity
- SpirVIEW Mobile™ Supervisory Software site security system

DETECTION AND IDENTIFICATION PERFORMANCE

- Gamma spectroscopy:
 - Detector: 2-liter NaI(Tl)
 - Energy range: 25 keV to 3 MeV
 - Energy resolution at 662 keV: typ. 7.5%
 - Cs-137 sensitivity > 23 cps/nSv/h
- Neutron:
 - Optional, integrated in the pillar
 - >130 cps / (N/s/cm²) for Cf-252 at 1 m
 - Detects 12,000 N/s, Cf-252 at 1 m and 1.2 m/s
 - Optional, separate neutron modules connected to gamma modules

SPIR-Ident™ Mobile Platform Airborne and Carborne Mobile Spectrometry

The SPIR-Ident Mobile Platform is an airborne and carborne system that combines advanced gamma detection and spectroscopy with optional neutron detection suited for vehicles, ships, helicopters and aircrafts.

FEATURES

- Real-time mobile search and identification of radioactive and nuclear materials, with integrated mapping
- Detectors: Gamma (2 or 4 L NaI) and Neutron (BZnS), scalable volumes (2-4-8-16 L) to meet end-use applications
- Stackable case enclosures
- Water/temperature/shock resistant, stackable enclosures
- Easily adaptive for Vehicle-Air-Marine use
- Instant configuration as a Pedestrian or Vehicle Portal Monitor
- Source-less Training Mode
- Integrated Flight or Mission Planning



DETECTION AND IDENTIFICATION PERFORMANCE

- Gamma spectroscopy: NaI(Tl) and GM
 - Sensitivity per detector (Cs-137)
 - 2 L : > 23 cps per nSv/h
 - 4 L : > 37 cps per nSv/h
 - Dose rate : 0.001 μ Sv/h to 9 999 μ Sv/h
 - Spectra: 1024 channels, from 25 keV to 3 MeV
 - Libraries of more than 75 nuclides
- Neutron: BZnS



Training

DMC 2000TD™ Electronic



SIM-TEQ™ SYSTEM

The Simulation Control Center (SCC) is a Windows 10-based application designed to run on a tablet (10 inches or greater), allowing complete flexibility to the instructor. Setup is quick and easy and requires no calibration of either the instruments or the system. The SIM-Teq system instruments either respond automatically to TWR (Two Way Ranging) simulated sources or they can be directly (manually) controlled through the SCC. Instructors can remotely monitor readings and status updates of every device, as well as control or configure any device(s) during a specific session. SIM-Teq system is fully scalable: as new instruments are developed, the SCC application is conveniently updated.

DMC 3000TD DEVICE

The DMC 3000TD device features all of the functions of an actually deployed DMC 3000 electronic dosimeter (including alarms, faults, and user interfaces) for extremely realistic training scenarios. It is fully configurable to match site RWP configurations, such as: rate alarm latching, time alarm, and threshold warnings. The DMC 3000TD unit even has the ability to attach dosimeter modules – such as the WRM2 Telemetry Module, to allow specific training of telemetry monitoring personnel. When paired with a Rad Tag, the DMC 3000TD device will auto-respond to the TWR simulator and mimic a dosimeter's behavior near simulated (non-radioactive) sources.





- ✓ Includes fully-functioning simulated instruments
- ✓ Full control over instrument response / functionality
- ✓ Direct response or automated response options
- ✓ Scalable application, to include future instruments



- ✓ Can be worn around neck or on belt
- ✓ Can be attached to modules for training
- ✓ Uses SCC to display measurements
- ✓ Used in conjunction with TWR Source

The SIM-Teq™ System is a wireless training network of simulated dosimeters, survey meters, and simulated (non-radioactive) sources managed and controlled by the Simulation Control Center (SCC) application.



Dosimeter Training Device

The DMC 2000TD unit is a fully functioning simulator of the DMC 2000S electronic dosimeter. Designed to be an effective and realistic training device, it replicates all dosimeter functions, alarms, and fault displays. It can even be used with existing WRM2 transmitters and alarm modules, allowing training of remote monitoring personnel.

FEATURES

NUCLEAR

- Range of Operation: ~100 ft line of sight

OPERATIONAL

- Audible Alarm: Same as DMC 2000S
- Wireless Communication: IEEE 802.15.4, 2.4 GHz, 18 mW

ELECTRICAL

- Battery: Renata CR 2450 lithium battery
- Battery Life: 8-30 hr, based on operating conditions

MECHANICAL

- Housing: Drop Resistant (1.5 meters on concrete)
- Dimensions: 3.4 x 21.0 x 1.1 in. (87 x 48 x 28 mm) max. without clip

DMC 3000TD™



Electronic Dosimeter Training Device

The DMC 3000TD unit is a fully functioning simulator of the DMC 3000 electronic dosimeter. Designed to be an effective and realistic training device, it replicates all dosimeter functions, alarms, and fault displays. It can even be used with existing WRM2 transmitter modules, allowing training of remote monitoring personnel.

FEATURES

NUCLEAR

- Range of Operation: ~100 ft line of sight

OPERATIONAL

- Alarming speaker with level of 85 dB (A) typical (> 90 dB (C) peak) at 30 cm (11.8 in.), frequency < 4800 Hz
- Wireless Communication: IEEE 802.15.4, 2.4 GHz, 18 mW

ELECTRICAL

- Battery: One AAA battery
- Battery Life: 8-30 hr, based on operating conditions

MECHANICAL

- Housing: Drop Resistant (1.5 meters on concrete)
- Dimensions: 3.4 x 2.3 x 0.8 in. (87 x 60 x 21 mm) max. without clip

SCC/Dongle

Simulation Control Center and Wireless Communication Dongle

The **Simulation Control Center (SCC)** is a Windows 10 application that uses a USB Dongle to remotely communicate with all models supported in the SIM-Teq product line of training devices. This intuitive application allows the direct control and configuration of each training device including; radiation levels, alarms, faults, dose and dose rate, etc. SCC provides a remote view of the measurements displayed on the controlled instrument.

FEATURES

- Display: Full screen and intuitive user interface
- Requirements: Any Windows 10 tablet (10 in. or larger display) or PC with a free USB port (recommended Microsoft Surface Pro tablet)



ICTD Model 9-4 Ion Chamber Training Device

Train your Radworkers to respond to dose rates based on distance to one or more TWR "live" sources.

FEATURES

- Simulates all features and functions of the Ludlum Model 9-4 Ion Chamber
- Built with real Model 9-4 hardware
- Provides all device controls and beta window
- Responds realistically to changes in dose rate
- Supports all fault conditions
- Designed for manual or automatic dose rate input
- Operates independently with any SIM-Teq TWR Source (omni-directional), OR manually controlled by instructor
- Ludlum external components include: meter movement, switches, case top, battery compartment, handle and case latches – looks, feels and responds like the real meter
- Display Range: Up to saturation (0 – 500mSv/h, 0 – 50,000mR/h)
- Response performance characterized from real instrument
- Functional 5-range selector switch, light, zero adjust, battery test and reset pushbutton features
- Functional Beta Window with default and programmable measurement offset
- NO calibration or setup required





TWR “Mini” Source Two Way Ranging “Live” Source of Radiation

Two Way Ranging technology continually measures distance from simulator instrument to adjust rate and dose automatically. Sources are small and easy to conceal.

No complicated setup - place source, turn on and start exercise. Select from custom combinations of isotopes for RID capable SIM-Teq training instruments. Configure dose rate “activity” at 1 foot. Deploy multiple sources and train with multiple devices simultaneously. Swap between automatic response to TWR sources to manual control with SCC.

FEATURES

- **NEW** Configurable isotopic mix of up to 5 isotopes from ANSI N42.34-2021 library
- Simulated point source of radiation – omni directional
- **NEW** Configurable neutron output in neutrons per second
- Automatic detection of source by instrument/ Rad Tag
- Dynamic response of simulator instrument to source based on $1/r^2$
- Select output from (10) customizable pre-configurations via pushbutton or SCC
- Background only output option
- Quick deployment in indoor or outdoor setting
- 100' range of detection
- Configurable gamma source activity 26 μ Ci to 26,000Ci Cs-137 source



Rad Tag “Mini” TWR “Live” Source to DMC Training Device Interface

Two Way Ranging (TWR) simulation technology continually measures distance from Rad Tag to source and calculates dose rate using $1/r^2$ principle. No instructor control required after dosimeter pairing.

Dosimeter readings are displayed automatically on the Simulation Control Center (SCC). Instructor can swap between auto-response of dosimeter to TWR sources and manual control using the SCC. Exercises can have one or more Rad Tag / dosimeter pairings.

FEATURES

- Wireless pairing of Rad Tag to any SIM-Teq dosimeter
- Automatic detection of TWR “Live” Source
- Continual input of dose rate measurements to training dosimeter and SCC
- 100' range of detection
- Small and easy to wear – about the size of a TLD badge
- LED battery charge indication

GMP-25TD™ Contamination Probe Training Device

Simulates features and functions of the Mirion GMP-25 External Pancake Probe when connected to SIM-Teq RDS-31TD device.

FEATURES

- Realistic response based on source/detector geometry
- Factory configurable simulated contamination type (α , β , $\alpha+\beta$) and level (up to 50,000 cps and greater for saturation demonstration)
- Use with any SIM-Teq RFID contamination source(s) OR respond to TWR source or control manually with SCC application

Train Your Radworkers To:

- Use proper frisking speed and probe-to-surface distance
- Observe elevated contamination levels on the meter
- Hear audible click rate as radiation levels change
- Assess if contamination has spread by using multiple contamination sources placed throughout an area
- Recognize elevated background interference and effects on performance when used with SIM-Teq TWR "live" source



Emergency Response and Preparedness

RADIATION BOUNDARY MONITOR DETECTION

An emerging area of interest in nuclear power emergency planning is the routine monitoring of site boundaries. Mirion's RBM™ Radiological Boundary Monitor is just such an instrument. Delineating a secure, measurable perimeter around the facility with alarm capabilities and remote data transmission, a network of RBM units alerts plant personnel in the event of any sort of radiological event or accident. These units can be housed in environmentally secure enclosures and equipped with long-lasting batteries or solar power, ensuring that they can be operated and monitored even from areas along a facility's perimeter that are typically difficult to access for survey purposes or emergency alerts.

The RBM unit is completely self-contained in a NEMA certified case, with its own solar power system.



The RBM detectors are located on a swiveling panel for easy access to the unit's back-up battery and micro-controller.



The detection panel can accommodate the RDS-32 unit's various extension probes to meet a variety of measurement needs.





- ✓ Rapidly deployable, self-contained kits
- ✓ Multiple instrument types (exposure, survey, etc.)
- ✓ Routine monitoring of site boundary with alerts
- ✓ Remote connectivity enables continuous awareness



Short Term Area Monitor Kit

The Short-term Area Monitor allows quick deployment for a few months (in outages, for example) – with regular (four seconds) WRM2 transmission – in a rugged package.

FEATURES

ELECTRICAL

- Power Supply:
 - The RDS-32iTx survey meter Short Term Area Monitor Kit uses twelve AA batteries. Image displays four AA battery pack, with additional batteries below the foam
 - The DMC 3000 dosimeter uses a AAA battery, with two D-cell batteries that connect via an external adapter to the Telemetry Module
- Battery Life: Provides three to four months of four second transmission

MECHANICAL

- Housing: Pelican TM case (for use in harsh environments) features a clear front for increased worker awareness if used for an Alarming Area Monitor
- Integrated WRM transmitter – no additional parts needed



RDS-32 Response Kit Self-Contained Emergency Survey Kit

This kit provides multiple survey meters in an “all-in-one” package. Detection is provided by Mirion’s versatile RDS-31 meter, along with an array of external probes to underwater deployment and beta smear frisking capability.

FEATURES

MECHANICAL

- Housing: All materials are self-contained in a rugged, environment-proof Pelican TM case
- Underwater (GMP-12UW) probe(s) included for use in harsh environments
- Two complete sets are provided for simultaneous dose rate detection and smear counting
- Smart probes allow any meter to be connected to any probe on the fly – just plug in and go!



DMC 3000 Response Kit Self-Contained Emergency Electronic Dosimetry Kit

This kit provides the ability to deploy a small population of electronic dosimeters from a field position (that is, without requirements for network and database connectivity). The included DMCUser Electronic Dosimeters Management and Maintenance Software assigns Mirion's flagship DMC 3000 dosimeter(s) to specific personnel, applies pre-set configuration parameters (alarm thresholds, etc.), and logs personnel exposure upon conclusion of the response. The kit also includes a touch screen computer to enable quick response to changing field conditions and data trending over longer deployments.

FEATURES

OPERATIONAL

- Display: Touch screen handheld computer
- DMCUser Electronic Dosimeters Management and Maintenance software included
- The software's data export function allows after-the-fact recording of personnel dose or analysis of team-based performance, etc.

MECHANICAL

- Housing: Complete system is self-contained in a rugged, environment-proof Pelican case
- Includes ten DMC 3000 electronic dosimeters and an LDM-320D dosimeter reader



RBM™ Radiation Boundary Monitor

Radiation Boundary Monitors are flexible, easy to operate systems that feature our RDS-32 handheld survey meters, they provide the valuable coverage needed to ensure comprehensive data collection around a nuclear facility.

Able to be fitted with a variety of power sources, from solar to battery to AC, and able to be networked with WRM2 radios and monitored using Mirion's TeleView 3000 software, the Mirion Radiation Boundary Monitors provide a powerful tool for keeping up with the changing requirements for site boundary monitoring.

FEATURES

DRM-2 Model

- Operating Temperature: -9 °C to 50 °C (15 °F to 122 °F)
- Storage Temperature: -20 °C to 60 °C (-5 °F to 140 °F)
- Relative Humidity: 10% to 95%
- Dose Rate Measurement Range: 0.05 mR/h to 999 R/h (0.5 µSv/h to 9.99 Sv/h)

RDS-31 Model

- Operating Temperature: -25 °C to 60 °C (-13 °F to 140 °F)
- Storage Temperature: -40 °C to 70 °C (-40 °F to 158 °F)
- Relative Humidity: Up to 85% at 35 °C (95 °F)
- Fulfills the RF-immunity levels of applicable standard
- Dose Rate Measurement Range (GM): 1 µrem/h to 10 rem/h (0.01 µSv/h to 0.1 Sv/h) or
- Dose Rate Measurement Range (SD): 1 mem/h to 1000 rem/h (10 µSv/h to 10 Sv/h)



SPIR-Ace™ Radionuclide Identification Device (RIID) with quantitative assessment capability

The SPIR-Ace unit is a versatile Radio Isotope Identification Device (RIID) addressing all applications requiring efficient detection and identification of radiological threats in security applications, including civil defense, border security and customs.

FEATURES

NUCLEAR

- NaI(Tl) version: dia 1.4 in. dia x 2 in. (35 mm x 51 mm)
- LaBr₃ (Ce) version: dia 1 in. dia x 1.34 in. (25.4 mm x 34 mm)
- Energy compensated GM tube for high gamma dose rate
- Optional neutron detector: moderated 6LiZnS: Ag scintillator
- Optional external alpha/beta GMP-25™ contamination probe

ELECTRICAL

- Li-ion rechargeable, built-in charger, replaceable
- Battery life: 8.5 hours (up to 15 hours with screen off most of the time)
- Charge time: 5 hours (device turned off) with regular 2.1 A/5 V USB adapter

OPERATIONAL

- Operating temperature range:
 - NaI: -20 °C to +55 °C (-4 °F to +131 °F)
 - LaBr₃: -20 °C to +50 °C (-4 °F to +122 °F)
- Humidity: 93% relative humidity at 40 °C
- Water and dust: IP65

MECHANICAL

- Weight: maximum (NaI and LiZnS detectors) 1.45 kg (2.2 lb)
- Dimensions: 8.1 x 6.2 x 2.2 in. (206 x 153 x 57 mm)



SPIR-Explorer™ Sensor Light Weight Wide Range Radiological Detection and Identification Sensor

The SPIR-Explorer sensor is a lightweight radiation detector designed to be mounted on a UAV/Drone or UGV/Robot for a wide range of applications where radiation detection, measurement, and nuclide identification is needed. This includes environmental surveys, military reconnaissance, Radiological Dispersal or Exposure Device (RDD or RED) detection, hospitals/industry fire hazards, nuclear power plant emergency response.

FEATURES

NUCLEAR

- Detectors:
 - Same as SPIR-Ace unit for the NaI and LaBr₃ NaI(Tl) dia 32 mm* 51 mm or LaBr₃(Eu) dia 25 mm* 32 mm
 - + 2 GM tubes (mid and high range)
- Measurement Range: 0,001 µSv/h to 10 Sv/h (0.1 µR/h to 1000 R/h)
- Energy Range: from 20 keV to 3 MeV

OPERATIONAL

- Display: No display
- Serial communications: Supplied with SPIR-Ident Suite software (SpirVIEW Mobile™ software) typically installed on a laptop (USB/

Serial cable) or remotely behind a wireless transmission+localization system.

ELECTRICAL

- Supply Voltage: typical 4.5 to 18 V
- Power consumption: ≤ 1 W

MECHANICAL

- Dimensions: 250 mm (L) x 132 mm (W) x 81 mm (H)
- Temperature Range: operation from -20 °C to 50 °C. Operates accurately under temperature shock
- Humidity: 93% HR at 30 °C



SPIR-Pack™ Man-portable Detection and Identification

Mirion's SPIR-Pack backpack is ideal for all applications requiring the efficient detection and identification of radiological and nuclear threats. These applications provide the protection for large public events, as well as readiness for radiological/nuclear interdiction.

FEATURES

NUCLEAR

- Detectors: NaI(Tl) detector: 2 in. diameter x 4 in. length (51 mm diameter x 102 mm length)
- Gamma sensitivity to Cs-137: 3500 cps/(μ Sv/h) or 35 cps/(μ R/h)
- Energy Range:
 - 25 keV to 3 MeV (gamma)
 - 0.0025 eV to 15 MeV (neutron)

SMARTPHONE FEATURES

- Android smartphone, GPS, Bluetooth@ technology, Wi-Fi, cellular communications
- Data available: real-time measurements and alarms, using industry-standard file formats (spe, n42, csv)

ELECTRICAL

- Li-ion rechargeable, 5300 mAh, 3.7 V, built-in charger
- Backpack battery life: G and GN lightweight: 24 h; GN: 13 h

MECHANICAL

- G and GN lightweight: 30.3 x 25 x 46 cm (11.9 x 10 x 18.1 in.)
- GN (sensitive): 11.4 x 7.9 x 20.3 in. (29 x 20 x 51.5 cm)

ENVIRONMENT

- Operating temperature range: -20 °C to +50 °C (-4 °F to 122 °F)
- Operating humidity: 93% at 40 °C (104 °F)

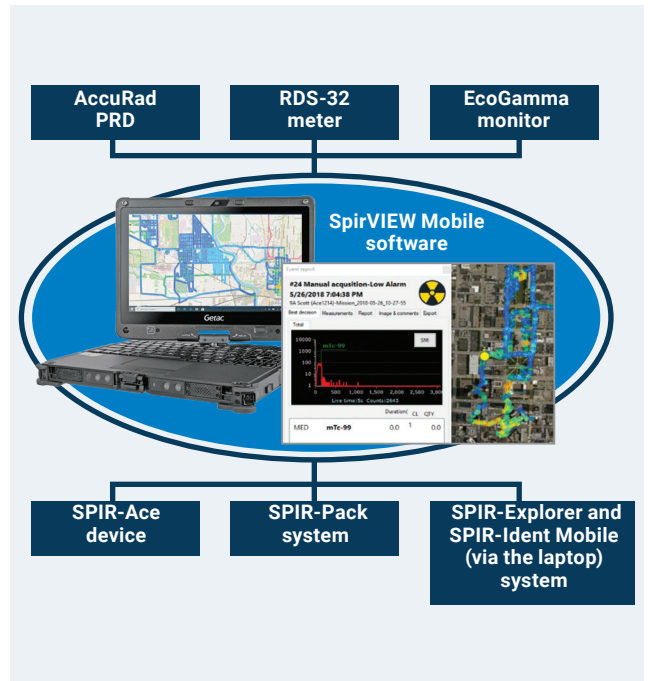

SpirVIEW Mobile™ Situational Awareness Software

The SpirVIEW Mobile software is designed for organizations and agencies responsible for monitoring and preventing nuclear and radiological terrorist threat. The SpirVIEW Mobile system manages monitoring of large scale events such as sport venues, conferences, conventions, critical infrastructure and more, providing area safety.

FEATURES

- Real-time radiological situational awareness
- Data fusion: pedestrians, ground vehicles, aircraft, marine vessels, UAVs, rovers, robotics
- Secured no-loss data transfer and storage
- Facilitate communication with the field and the regulatory authorities
- Remote alarm confirmation (Reachback)
- Data server hosted by the user's organization (physical or cloud-based)



Airborne Radiation Monitoring

ABPM 203M MONITOR

A self-contained, mobile unit able to be easily and quickly deployed into any area as conditions require, the ABPM 203M™ unit is an airborne radiation contamination monitor measuring both alpha and beta particulates with up-to-the-minute tracking of the radiological conditions in the air. The ABPM monitor features on-board identification and optional subtraction of Radon progeny, and includes a second gamma only detector to allow usage in virtually any level of radiological background. Capable of being configured with WRM2 wireless technology, the ABPM unit's data can then be transmitted back to a central control area where it can be interpreted and used to inform operational decisions without any of the typical delays caused by cumbersome deployment, longer-term readings, or communication breakdowns.



Automatic moving filter head can be located up to 30 ft away



LPDU displays live time data (alpha, beta, background dose rates, and flow rate) along with audible and light signaling

- ✓ Rapidly deployable, self-contained kits
- ✓ Multiple instrument types (exposure, survey, etc.)
- ✓ Routine monitoring of site boundary with alerts
- ✓ Remote connectivity enables continuous awareness

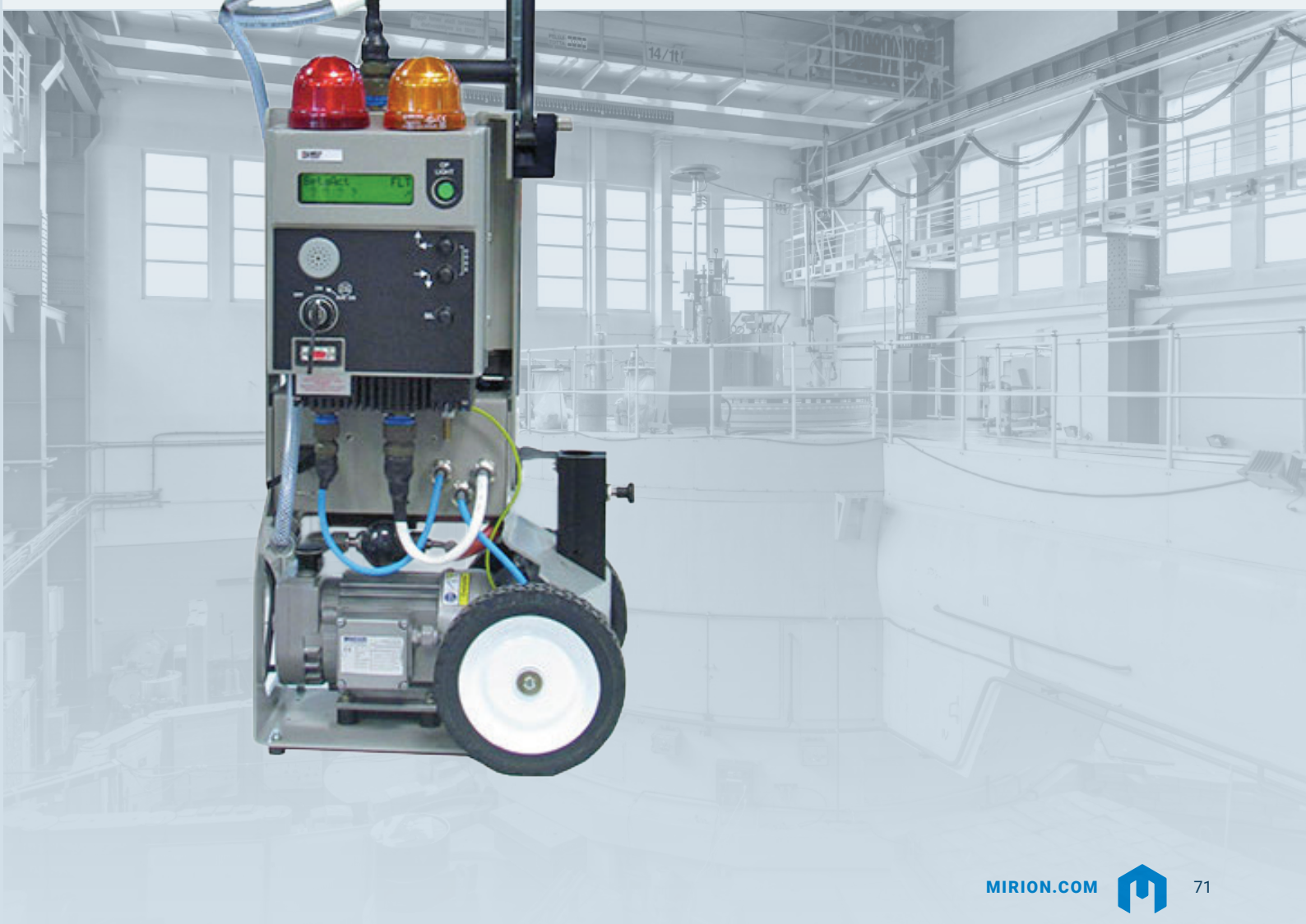



ABPM 203M™ Mobile Alpha Beta Particulate Monitor

The ABPM 203M monitor forms part of the RAMSYS™ product line. The detector is small and lightweight and allows this monitor to function locally next to the respiratory tract of workers. A dual silicon detector performs the gamma compensation and a radial fin grid limits the scattering of the alpha particles (static compensation) which facilitates the compensation of the radon and thoron solid progenies by the processing algorithms (dynamic compensation). Operating costs are minimized through unattended operation, by the use of continuous filter and the on-line spectroscopy capability. All these features make the ABPM 203M unit an efficient diversified and cost effective tool.

FEATURES

NUCLEAR

- Measurement Range:
Alpha $2.7 \cdot 10^{-13}$ to $10^{-4} \mu\text{Ci/cc}$
Beta $2.7 \cdot 10^{-11}$ to $10^{-4} \mu\text{Ci/cc}$

OPERATIONAL

- Display: Alphanumeric; measurement, status...
- Visual: Two lights (Red and Yellow)
- Audible Alarm: Buzzer 90 dBA at 39.3 in. (1 m)

ELECTRICAL

- Power Supply: 230 V ac – 50 Hz or 120 V ac – 60 Hz

MECHANICAL

- Dimensions: 50 x 14.2 x 12 in. (1270 x 360 x 303 mm)
- Weight: ~57 lb (~26 kg)

Other Version:

- Fixed filter model



NGM 209M™ Mobile Low Range Noble Gas Monitor

The NGM 209M monitor from the RAMSYS product line has been developed to sample air in discharge stacks or ventilation ducts. The dual silicon diode detector integrated in a $4\pi/1.18$ in. ($4\pi/3$ cm) lead shielded sample volume guarantees high reliability of the measurements. The first silicon diode detects the beta/gamma radiation from sample volume and the gamma ambient radiation (background). The second one detects gamma radiation from the sample volume and the gamma ambient radiation. This allows noble gas beta measurement with dynamic gamma compensation by the processing algorithms.

FEATURES

NUCLEAR

- Detector: Dual large area silicon
- Measurement Range: 10^{-6} to $2.7 \cdot 10^{-1} \mu\text{Ci/cc}$

OPERATIONAL

- Display: Alphanumeric; measurement, status...
- Visual: Three lights (Red, Yellow and Green)
- Audible Alarm: Buzzer 90 dBA at 39.3 in. (1 m)

ELECTRICAL

- Power Supply: 230 V ac – 50 Hz or 120 V ac – 60 Hz

MECHANICAL

- Dimensions: 50 x 14.2 x 12 in. (1270 x 360 x 303 mm)
- Weight: ~66 lb (~30 kg)



IM 201M™ Mobile Iodine Monitor

The IM 201M monitor forms part of the RAMSYS product line. It has been developed to continuously measure the gamma volumetric activity of radioactive iodine sample, in both molecular and organic forms (methyl iodine), contained in air drawn from stacks, ventilation ducts or working areas. An NaI scintillation detector faces the activated charcoal cartridge in which radioactive iodine is trapped. The proximity of the detector and the cartridge, enclosed with a $4\pi/2$ in. ($4\pi/5$ cm) lead shielding, serves to optimize detection efficiency. A radioactive ^{241}Am source built into the NaI crystal allows compensation of temperature and aging related drifts. The spectrometry capability, based on a 1024 channel spectrum analysis allows radio iodine isotope localization.

FEATURES

NUCLEAR

- Detector: 1 ¼" x 1" NaI(Tl) scintillator + PMT
- Measurement Range: 10^{-10} to 10^{-4} $\mu\text{Ci/cc}$

OPERATIONAL

- Display: Alphanumeric; measurement, status...
- Visual: Three lights (Red, Yellow and Green)
- Audible Alarm: Buzzer 90 dBA at 39.3 in. (1 m)
- 1024 channel spectrum analysis

ELECTRICAL

- Power Supply: 50 Hz or 120 V ac – 60 Hz

MECHANICAL

- Dimensions: 55.4 x 20.5 x 27.6 in. (1406 x 520 x 700 mm)
- Weight: ~441 lb (~200 kg)



iCAM™ Mobile Alpha Beta Particulate Monitor

The iCAM intelligent alpha beta continuous air monitor forms part of the CAMSYS™ product line. It provides robust and reliable monitoring of airborne alpha and beta particulate activity in the workplace. It acts as a simple alarming monitor for operators, while measuring airborne activities in real time with the sophistication required to provide low false alarm rates and high protection levels. At the same time it provides automated facilities which assist supervisors to conduct detailed setup and operational overview.

FEATURES

NUCLEAR

- Detector: Dual PIPS large area silicon assembly in option
- Measurement Range: In excess of 500 kBq ($13.5 \mu\text{Ci}$) of combined alpha and beta activity deposited on the filter

OPERATIONAL

- Airflow Measurement: Electronic mass flowmeter, of range 15 to 60 L/min. (0.5 to 2.1 ft^3/min .)
- Typical Indicated Flow Rate: 37 L/min. (1.3 ft^3/min .), controlled by the optional manual flow control valve

- Low and high flow rate limits adjusted by user differential filter pressure alarm 50 mm Hg (25 in WG)

ELECTRICAL

- AC Mains Frequency: 47-63 Hz
- Voltage: 100-240 V ($\pm 10\%$)
- Power Consumption: 46 VA

MECHANICAL

- Dimensions: 9.6 x 21 x 6.7 in. (245 x 535 x 170 mm)
- Weight: 26 lb (12 kg) without vacuum pump

Software

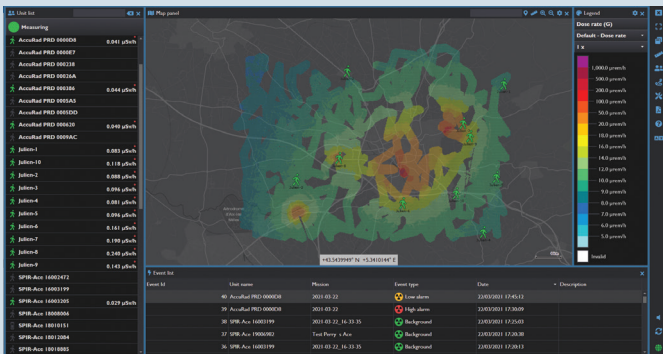

SpirVIEW Mobile™ Situational Awareness Software

The SpirVIEW Mobile software is designed for organizations and agencies responsible for monitoring and preventing nuclear and radiological terrorist threat. The SpirVIEW Mobile system manages monitoring of large scale events such as sport venues, conferences, conventions, critical infrastructure and more, providing area safety.

FEATURES

- Real-time radiological situational awareness
- Data fusion: pedestrians, ground vehicles, aircraft, marine vessels, UAVs, rovers, robotics
- Secured no-loss data transfer and storage
- Facilitate communication with the field and the regulatory authorities
- Remote alarm confirmation (Reachback)
- Data hosted by the organization

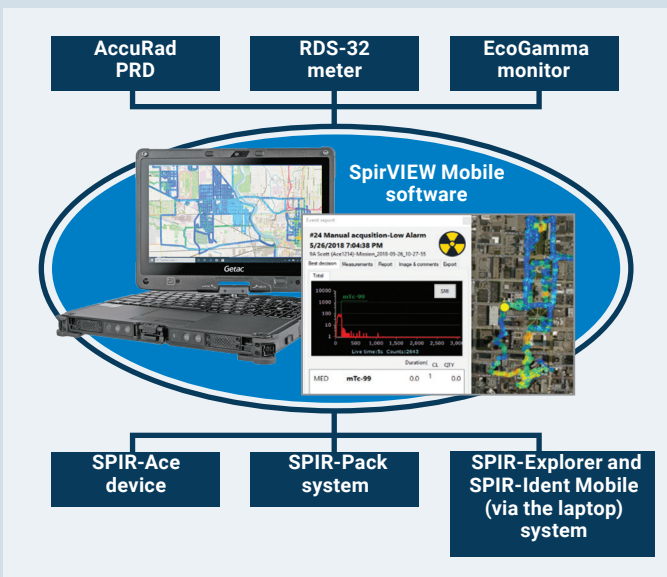

Download the Mirion apps to connect your RDS-32™ meter and AccuRad™ PRD to SpirVIEW Mobile™ Supervisory Software and the RadResponder Network

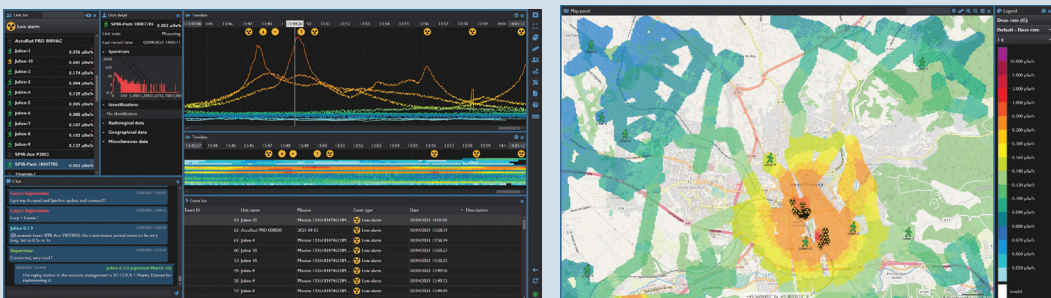

SpirVIEW Mobile multi-screen use.

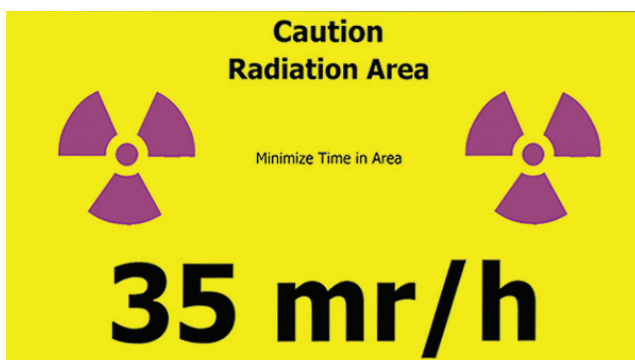

RPD™ Radiological Posting Display Software

The RPD Software is a hardware and software solution providing the ability to display area monitor data real time on a large screen display. It was developed using the previous software, the Large Format Device Display as a base and still supports all of the original functionality. In addition, new screens were developed to be used as a Posting Display. A set of four screens can change the appearance of the resultant display based on the dose rate found in the area being monitored.

FEATURES

- Dynamic display of ambient radiological conditions
- Display up to four instruments at one time
- Can be setup to display radiological posting that will automatically change based on the dose rates in the area
- Network or directly connect devices
- Quick and easy setup, designed for all WRM2 devices

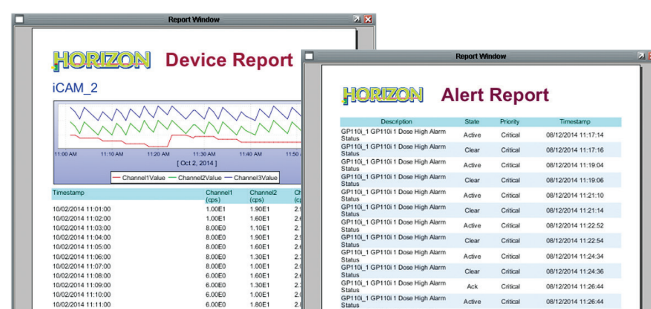

Horizon® Supervisory System Software

Horizon system is a real-time data acquisition and control system that provides supervisory oversight of your radiological instruments.

FEATURES

- Comprehensive supervision for your radiological instrument network
- Built-in support for the Mirion Environmental and Radiation Monitoring Systems as well as Personnel/Object Contamination Monitors
- Flexible client configuration allows creation of situational and navigation screens specific to your site
- Robust, platform neutral SCADA tools provide advanced graphic controls for visualizing your data
- Instrument screens are tailored for each device ensuring access to monitor setpoint and operation information
- Fully integrated design tool and reporting function



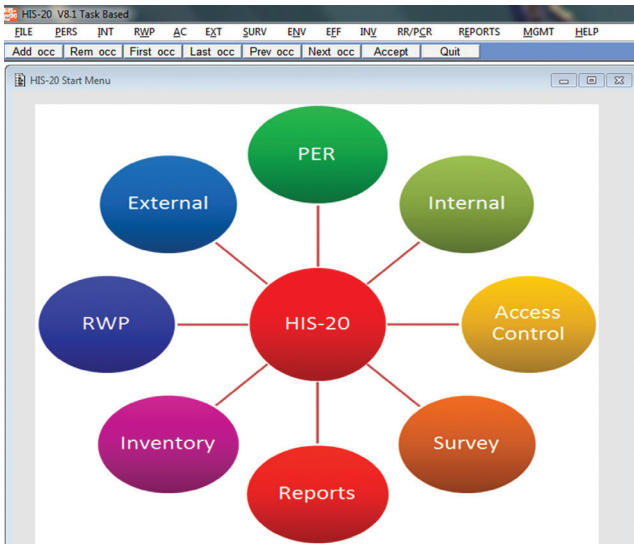

HIS-20™ Health Physics Information Record Keeping System

HIS-20 system is a complete Health Physics Information package that is designed to incorporate the latest requirements as specified by regulating agencies. It is designed to minimize or eliminate the amount of customization necessary to meet site-specific requirements. The database allows the site's HIS-20 manager to choose functional parameters and to set up lookup tables specific to site operations.

FEATURES

- Set the application up to work the way your site operates through setup/lookup tables and site parameters
- User customizable with shortcuts to favorites, dashboards queries and other setup tables
- Robust security implementation
- Tracks individual exposure
- Generates Radiation Work Permits
- Performs Access Control manually or through the Windows Access Control Station software
- Ties Survey to RWPs to calculate intake data
- Flexible interface to external systems (imports demographic data, training data, TLDs or OSLDs, PADS, and more)

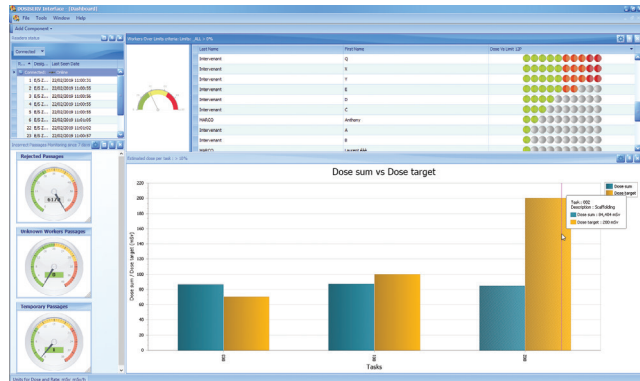

DosiServ™ Dose Management Software

The DosiServ software is an individual and collective dosimetry management software used for managing all the data related to the workers in controlled areas. It also collects the data recorded by the electronic dosimeters by using the dosimetry readers.

FEATURES

- Real-time self access with threshold customization
- Tasks and group of tasks management
- Radiation work permit management
- Areas, sub-areas and group of areas management
- Worker and company access criteria customization
- Worker data customization
- Official dose calculation customization for various legislation compliance
- Neutron electronic dosimeter compliance
- Health physics equipments management
- Automatic dose recovery after network failure

UserID	RWP	Task	Status	Dose	Rate	TStamp	Tx	Wrench
Alpha 11			Good	1.2 mrv	0 mch/y	14.06.00	1.5V	00:00:00
Alpha 3			Good	0 mrv	0 mch/y	14.06.00	1.5V	00:00:00
WHITE PERRY 1	1		Good	0.5 mrv	0 mch/y	14.06.00	1.5V	00:00:00
Alpha 8			Good	0 mrv	0 mch/y	14.06.59	1.5V	00:00:00
Alpha 9			Good	0 mrv	0 mch/y	14.06.59	1.5V	00:00:00
NOST_JMI	0163		Good	0.3 mrv	0 mch/y	14.06.58	1.5V	02:15:00
Alpha 2			Good	0 mrv	0 mch/y	14.06.58	1.5V	00:00:00
NOST_JMI	0163		Good	7.3 mrv	0 mch/y	14.06.57	1.5V	00:00:00
Alpha 5			Good	0 mrv	0 mch/y	14.06.57	1.5V	00:00:00
Alpha 7			Good	0 mrv	0 mch/y	14.06.57	1.5V	00:00:00
Alpha 5			Good	0 mrv	0 mch/y	14.06.56	1.5V	00:00:00
Alpha 10			Good	0 mrv	0 mch/y	14.06.56	1.5V	00:00:00
365068			Good	4.7 mrv	0 mch/y	14.06.53	1.5V	00:00:00
Alpha 4			Good	0 mrv	0 mch/y	14.06.52	1.5V	00:00:00
Alpha 9			Good	0 mrv	0 mch/y	14.06.50	1.5V	00:00:00
Task 2			Good	0.3 mrv	0 mch/y	14.06.50	1.5V	00:00:00
Alpha 1			LOST (Good)	0 mrv	0 mch/y	14.01.27	1.4V	00:00:00
300355			LOST (Good)	0.2 mrv	0 mch/y	09.02.44	1.5V	00:00:00

TeleView 3000™ Web Based Remote Monitoring System Software

TeleView 3000 software is Mirion's flagship Remote Monitoring application. Completely redesigned for the next generation of Radiation Protection support, it builds upon the familiar features expected from Remote Monitoring software (e.g., worker grouping by RWP, automatic worker logon via Access Control link, area monitor grouping, etc.) and adds updated features such as multiple windows / tab viewing, as well as GPS overlay functionality.

FEATURES

- Browser based Remote Monitoring application
- Cross-browser-TCP/IP support for multiple sessions
- Networked or stand-alone capability
- Intranet with security level support
- No requirement for workstation database
- Supports multiple telemetry data protocols
- Access Control connectivity for auto-logon features
- GPS supported, with overlaid map view
- Configurable data trending capability
- User configurable for greater flexibility and convenience
- Emergency Planning Perimeter Monitoring system (real-time boundary / offsite monitoring for RP teams)
- Monitors over 1000 devices



DosiFFR™ First Responder's Dosimetry Management System Software

Designed specifically for the rapid-deployment needs of First Responders, DosiFFR software is an application that tracks the issuance of electronic dosimeters to personnel, applies the appropriate configuration settings (alarm thresholds, etc.), and logs the dosimetry data from a given use.

FEATURES

- Designed for in-field use (self-contained)
- Can be configured for civil or military applications
- Manages individuals, dosimeters, and exposure data
- Data can be exported to an external reporting system
- SQL-based (free version) for easy implementation
- Dosimeter parameters can be pre-grouped into profiles

Software for Contamination Monitors

CeMoSys™ 2.0 Central Monitoring System Software

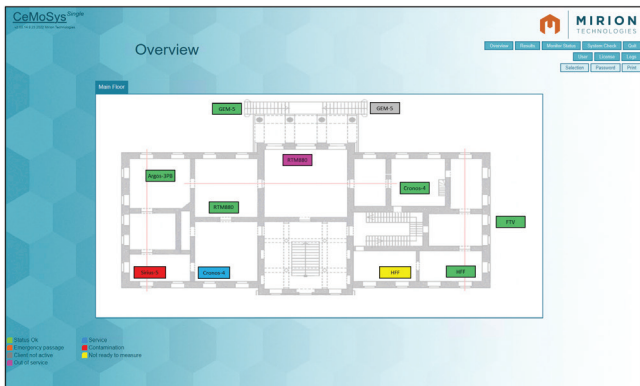

CeMoSys system is a central monitoring software platform for the display and administration of connected Mirion contamination and clearance monitoring systems and a facility network. CeMoSys 2.0 is compatible with all Mirion Contamination and Clearance monitors, including Argos-3/-5, GEM-5, Cronos-1/-4/-11, Sirius-5 systems.

FEATURES

- Monitor status overview for most Mirion Contamination and Clearance monitor families
- Measurement results and details on remote desktops
- Management of System Check protocols
- Overview of current measurement parameters on monitors
- Data backup for measurement results, parameter and system check protocols for all monitor families on site

Dashboard™ Web-based Monitor Overview Interface

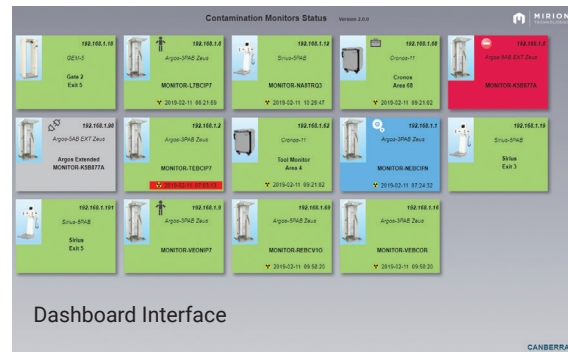

- Included for the following equipment:
 - Argos-3/-5 Whole Body Contamination Monitors
 - Sirius-5 Hand and Foot Monitors
 - GEM-5 Gamma Exit Monitors
 - Cronos Gamma Object/Tool Monitors
- Provides color-coded status overview of all networked contamination monitors on one screen
- Access via Internet Explorer or Firefox from any PC linked to the monitor network (Ethernet or WiFi) without any proprietary program or interface
- Contamination monitors can be selected from Dashboard system to inquire the details, and to change the parameters remotely through the WebRemote interface
- Included with Version 9.0x of Monitor Software or greater

WebRemote® Contamination Monitor Interface

- Included for the following equipment:
 - Argos-3/-5 Whole Body Contamination Monitors
 - Sirius-5 Hand and Foot Monitors
 - GEM-5 Gamma Exit Monitors
 - Cronos Gamma Object/Tool Monitors
- Provides intuitive user interface to monitor results, change parameters and view status of monitors with the system's touch screen or from anywhere in the facility using a desktop or a tablet PC
- Offers graphical selection of detectors for setup and calibration
- Any contaminated regions can easily be identified by the user
- Included with Version 9.0x of Monitor Software or greater



WebRemote Interface

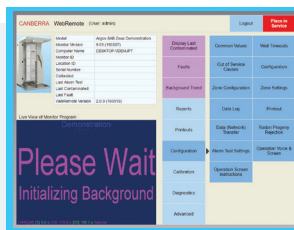

- Color-coded status:**
- Green – operational
 - Red – out of service
 - Magenta – contaminated
 - Gray – maintenance mode
 - Black – offline



Database Options

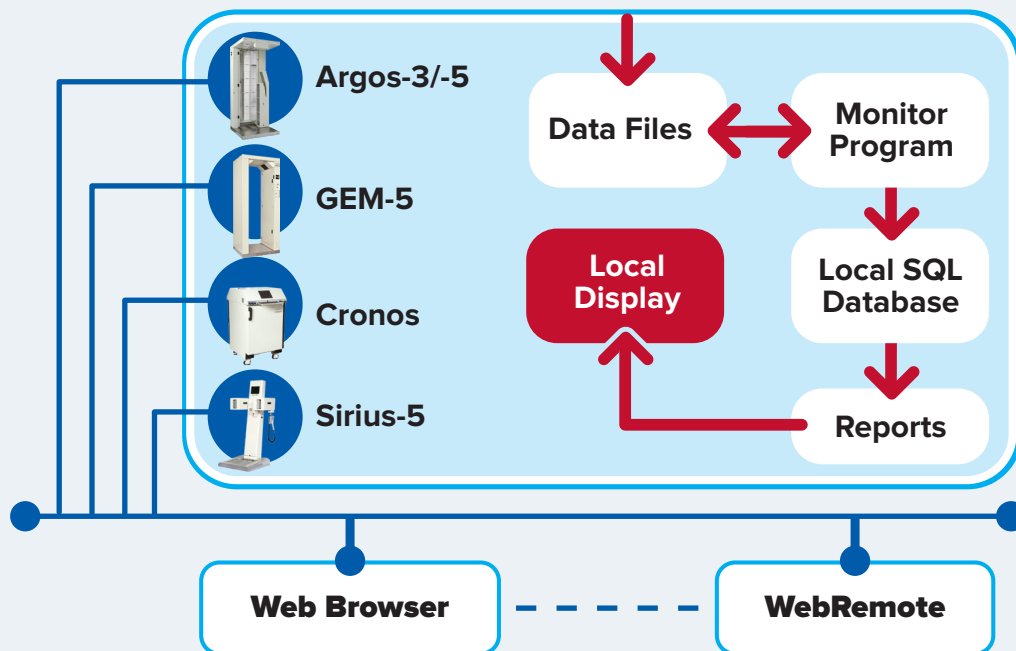

SOFT-LDB™ Local Database Support for Argos/GEM-5/Sirius/Cronos Contamination Monitors

SOFT-LDB support provides a data repository for the contamination monitor program and aids in the effectiveness of the Health Physics program by providing useful information at a glance. It includes an SQL Database with advanced reports which can be viewed locally on the monitor display or remotely using a web browser or WebRemote interface.

- **SOFT-LDB Local Database Support; Factory Installed**
- **SOFT-LDB-KIT Local Database Support; Field Installed**
 - Prerequisite: Windows 7 Embedded PC
- **SOFT-LDB-KITPC-A Local Database Support; Field Installed**
 - For existing Argos-3/-5, Sirius-5 or or Cronos monitors
 - Includes factory configured Windows 7 Embedded PC
- **SOFT-LDB-KITPC-G Local Database Support; Field Installed**
 - For existing GEM-5 Serial and GEM-5M monitors
 - Includes factory configured Windows 7 Embedded PC

Geiger Mueller Detectors

As an end user of Geiger Mueller detectors for over 60 years, we have successfully bridged the gap between technical conception, detector design and field application to achieve quality performance.

PROVEN DETECTOR EXPERIENCE

Our outstanding line of Geiger Mueller detectors, including 2000 Series pancake detectors, offers quality and reliability. Our detectors meet and exceed customer needs in laboratory, military and harsh industrial environments.

Mirion Geiger Mueller detectors offer superior performance, reliability and long-term stability. Our extensive product line provides direct (or near equivalents) for industry-standard detectors, including all versions of pancake detectors and frisker probes.

MANUFACTURING EXCELLENCE

Mirion's manufacturing operation has refined the development and production of GM detectors with state-of-the-art instrumentation and the finest equipment to monitor and control all manufacturing processes. Our attention to every detail ensures contamination-free assemblies. We use only the highest quality materials to fabricate critical detector components.

Our adherence to stringent design parameters and quality assurance ensures performance that meets or exceeds exacting commercial and military standards.

Mirion's growing detector division can offer substantial volume cost reductions for large orders.

TEST CIRCUITS

Use HV+, Ra and R1 from the chart.

Figure 1 - Anode Output

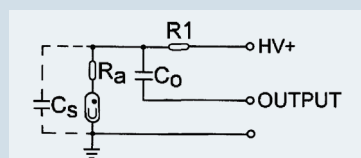

Cs = Stray capacitance typically < 1 pF.
Co = High voltage blocking capacitor.

Figure 2 - Cathode Output

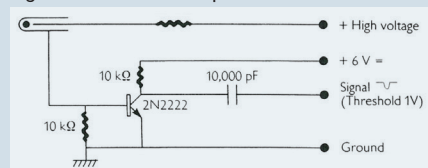

Temperature: +25 °C (77 °F)
Counting rate: 100 c.s⁻¹

PLATEAU CALCULATIONS

Plateau slope is calculated using the formula below, and given in units of percent change per 100 V.

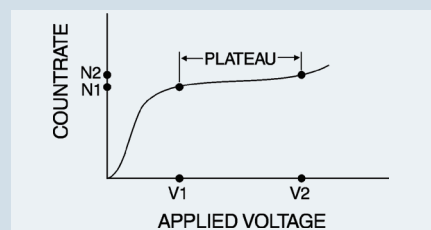

$$\frac{N2-N1}{1/2(N1+N2)} \times \frac{100}{V2-V1} \times 100 = \% \text{ per } 100 \text{ volts}$$

ALPHA PARTICLE DETECTION

The table below shows the initial energy required to penetrate a given mica window thickness. This assumes a negligible air gap between the source and the window. Note the range of alpha particles of various energies in air at atmospheric pressure.

Mica Window	α Energy	α Range in Air
1.0 mg/cm ²	1.9 MeV	10 mm
2.0 mg/cm ²	2.6 MeV	15 mm
3.0 mg/cm ²	3.6 MeV	22 mm
4.0 mg/cm ²	4.5 MeV	29 mm



PRODUCT RELIABILITY

- The Mirion Geiger Mueller detector has been carefully researched and developed to provide a rugged, reliable, long-lasting means of monitoring nuclear radiation levels. These detectors offer guaranteed advantages, including manufacturing consistency, product reliability and competitive pricing. Many of our detector types are manufactured and tested to withstand rigorous shock and vibration per military standards.
- All Mirion GM detectors comply with our stringent quality assurance policies, consistent with ISO 9001.

OUR WARRANTY

- Mirion warrants that its Geiger Mueller detectors will be free from defects in materials and workmanship for a period of one (1) year from the date of initial shipment.

BETA PARTICLE DETECTION

The chart below shows the effects of mica window thickness (mg/cm²) on beta particle absorption percentage.

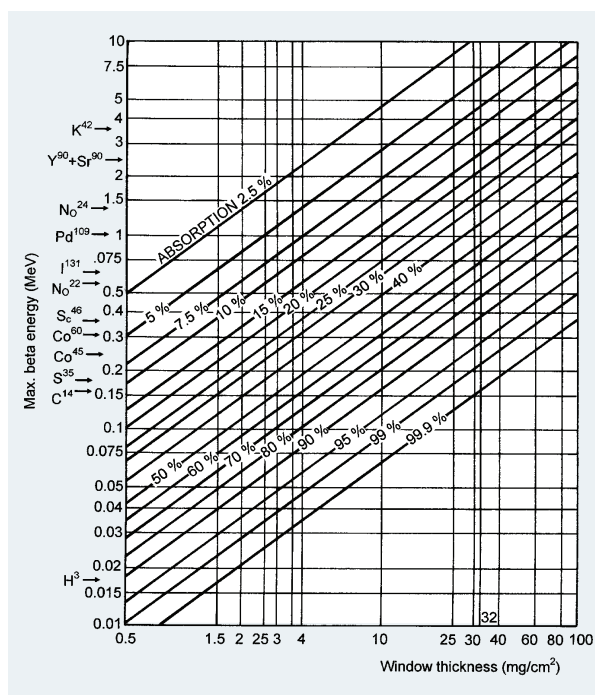

DEAD TIME CORRECTION

GM detectors using conventional counting circuitry all exhibit counting losses due to the Dead Time factor. These factors cited in the Mirion detector data tables are based on the recommended operating voltages and test circuits. The chart below enables the user to estimate the counting losses due to the Dead Time factor at high count rates.

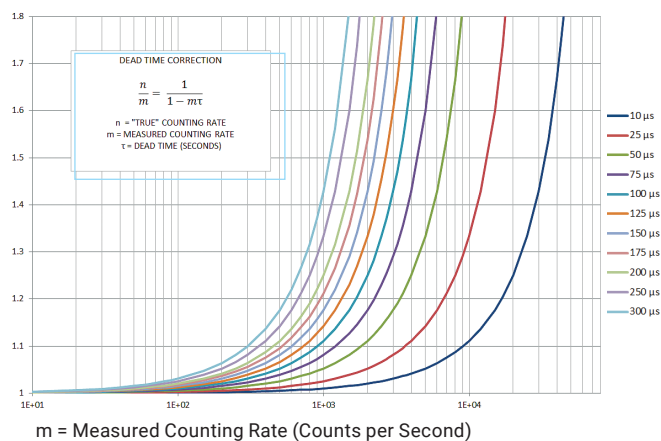

Performance Data

Pancake Detectors – For α , β , γ Applications

Characteristics	Detector Type				
	T2000/8767	T2000/500*	T2006/900	T2006/500*	T2007/500*
Application	α , β , γ				
Sensitivity*** ¹³⁷ CS cpm at 1 mR/h	3500				
Window Area Density (mg/cm ²)	1.8–2.0	1.8–2.0	2.0–2.2	2.0–2.2	2.0–2.2
Window Effective Diameter (mm, in.)	44.5, 1.75				
Recommended Operating Voltage	900	500	900	500	500
Plateau Length Volts min.	850-1000	450-600	850-1000	450-600	450-600
Plateau Slope (%/100 V max.)	10				
Dead Time (μ s max.)	50				
Background (c/m)*** Shielding 2" Pb + 1/8" Al	30 max.				
Test Circuit	Figure 1				
Resistor, Ra (MW)	3.3				
Resistor, R1 (MW)	1.0				
Operating Temp (°C)	-20 to +55				
Cathode Material	Cr/Fe				
Window Recess (mm, in.)	1.6, 0.062				

Pancake Detectors:

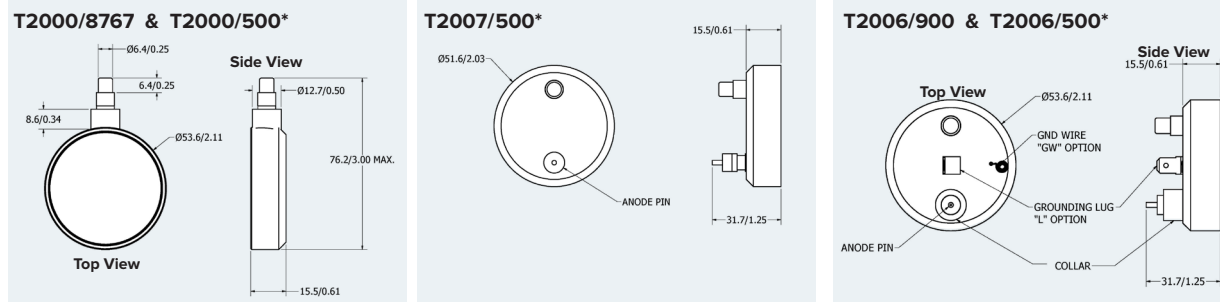

- * Alternate grounding options available.
- ** Energy compensated versions available.
- *** At recommended operating voltage.

Mica End Window – For α , β , γ Applications

Characteristics	Detector Type
	T2121**
Application	α , β , γ
Sensitivity*** ¹³⁷ CS cpm at 1 mR/h	1700
Window Area Density (mg/cm ²)	1.8–2.0
Window Effective Diameter (mm, in.)	19.8, 0.78
Recommended Operating Voltage	500
Plateau Length Volts min.	450-650
Plateau Slope (%/100 V max.)	5
Dead Time (μ s max.)	100
Background (c/m)*** Shielding 2" Pb + 1/8" Al	30 max.
Test Circuit	Figure 1
Resistor, Ra (MW)	3.3
Resistor, R1 (MW)	1.0
Operating Temp (°C)	-40 to +75
Cathode Material	Cr/Fe
Cathode Wall	1.3, 0.050
Window Recess (mm, in.)	1.6, 0.062

Mica End Window:

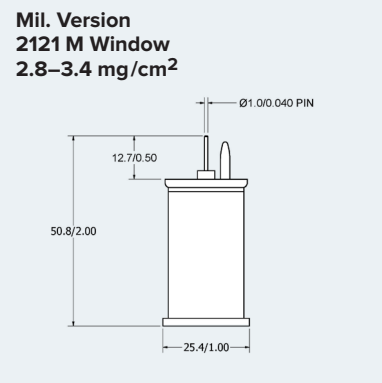

Gamma Sensitive Miniature Detectors – For γ Applications

Characteristics	Detector Type	
	T2420**	T2121**
Application	γ	
Sensitivity*** ¹³⁷ CS cpm at 1 mR/h	4.2	270
Recommended Operating Voltage	500	460
Plateau Length Volts min.	450-550	420-520
Plateau Slope (%/100 V max.)	35	30
Dead Time (μ s max.)	20	60
Background (c/m)*** Shielding 2" Pb + 1/8" Al	6 max.	25 max.
Test Circuit	Figure 2	
Resistor, Ra (MW)	4.7	
Resistor, R1 (MW)	N/A	
Operating Temp (°C)	-51 to +71	-20 to +60
Cathode Material	Cr/Fe	
Cathode Wall	360-400 mg/cm ²	280 mg/cm ²

Gamma Sensitive Miniature Detectors:

T2420**

To achieve maximum linear count rate, always solder Ra directly to the anode flying lead.

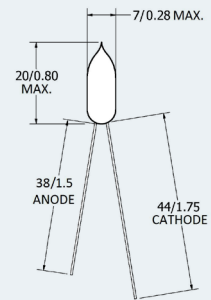

T3G6500-1

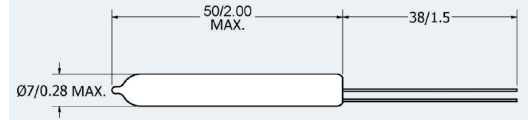

** Energy compensated versions available.
 *** At recommended operating voltage.

Ordering Information

Pancake Detectors

Part Number	Notes
T2000/8767	—
T2000/500	—
T2000/500GW	T2000/500 with Ground Wire
T2006/500	—
T2006/500-NC	T2006/500 without Anode Support Collar
T2006/500GW	T2006/500 with Ground Wire
T2006/500GW-NC	T2006/500GW without Anode Support Collar
T2006/500L	T2006/500 with Ground Lug
T2006/500L-NC	T2006/500L without Anode Support Collar
T2006/900	—
T2007/500	—
7084948	T2007/500 with Ground Wire with Solder Lug

End Window Detectors

Part Number	Notes
T2121	—
T2121M	Military Version, Mica Thickness: 2.8-3.4 mg/cm ²
D102130	Energy Compensated T2121M, for RDS-110
9303666A	Energy Compensated T2121M, for ADM300
9335514A	Energy Compensated T2121M, for ADM300SI
T2121MG	T2121 with 0.0125" Metal Window

Miniature Detectors

Part Number	Notes
T2420	—
9302553A	Energy Compensated T2420, for ADM300
7085395	Energy Compensated T2420, for NASRAMS
7086975	Energy Compensated T2420, for Seawater Probe
D3085197-GRN	Energy Compensated T2420 in Green Housing
D3085197-YEL	Energy Compensated T2420 in Yellow Housing
D703386-01	Energy Compensated T2420 in Gray Housing
T3G6500-1	—

Characterization Services

Mirion offers a large range of on-site services from dose rate and gamma imaging surveys to complex gamma spectroscopy and neutron measurements. Some of our instruments and systems are available for lease.

EXPERT SUPPORT FOR COMPLEX SYSTEMS

- ✓ Technical and feasibility studies to assist in waste management and D&D strategies, audit preparation and assistance, NDA system upgrade, system training.

METHOD DEVELOPMENT

- ✓ Best approach and methodology to achieve the customer's objectives, best practice approach.

MEASUREMENT PROCEDURES

- ✓ Operating instructions, documentation and training to provide QA approved methods for operators.

SYSTEM CALIBRATION SERVICE

- ✓ Initial or Annual calibration for installed systems, system qualification and certification.

ONSITE MEASUREMENT SERVICES AND CHARACTERIZATION REPORTS

- ✓ Large range of onsite services from dose rate and gamma imaging surveys to complex gamma spectroscopy and neutron measurements. Some of our instruments and systems are available for lease.

ASSISTANCE TO SYSTEM OPERATIONS

- ✓ Enhancing the operation of your NDA systems with the support of our Experts, providing assay systems for measurement campaign.

EXPERT DATA REVIEW

- ✓ Expert physics review of assay system results with QA and fingerprint reviews.



CSM-GR1™ Continuous Spectroscopic Monitor



iPIX™ Gamma Camera



GR1™ Compact CZT Spectrometer

Gamma Spectroscopy Services

High and/or low resolution spectroscopy measurements depending on application requirements. HPGe, NaI, LaBr, CZT etc., combined with ISOCS™ calibration in transportable or handheld configurations

Sometimes wastes are generated by events – spills, accidents or various pieces of equipment and articles that may be contaminated. Where it is not convenient to transport the waste material to a fixed system (or as a prescreen before packaging for full assay and disposal), Mirion provides a service for in situ measurement. Combined with ISOCS In Situ Object-Counting this type of system offers transportability as well as the ability to identify and quantify nuclide activities in samples of unusual or large geometry.

High-Level Radioactivity Measurements

A combination of measurement techniques and extended ISOCS applications have been used to solve challenging high-activity measurement situations. The GR1 CZT detector is ideal for these measurements, and as it has been ISOCS characterized can be used in a variety of measurement configurations.

Additionally, Gamma Camera Imaging can be used to provide critical information in real time on the source distribution (hot spots, layering) that can be incorporated into the ISOCS modeling.

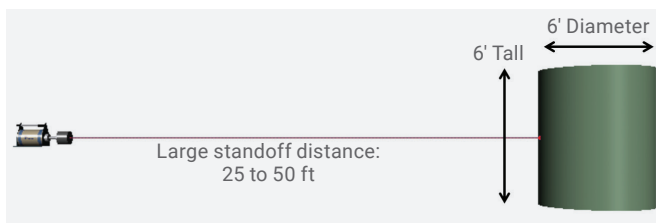

High Dose Rate Resin-Loaded Poly Liners

An ISOCS system with a pinhole collimator is shown modeled to measure Ion Exchange Resins with contact dose rates in the range of 10 to 200 R/hr where traditional sampling did not provide adequate results.

On-site Services

Mirion offers a wide range of In situ measurement services for which our specialists bring any required assay equipment to the customer site for the duration of the project.

The service includes management of the full life cycle of such activities from the specification of the radiometric measurement solution through the analysis and reporting of the final results.

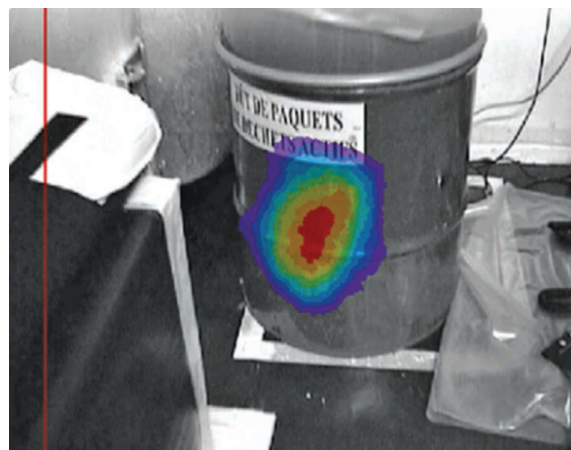

Challenging Characterization Situations

Our measurement services team can apply custom software tools to accomplish the following:

- 1. Improving accuracy** – By optimizing the determination of the efficiency calibration most consistent with the gamma-ray spectrum measured in the field.
- 2. Measuring unusual structures/shapes** – By adapting the standard geometry composer to accommodate complex models like plated depositions.
- 3. Integrating with waste assay** – By using custom scripts to integrate and automate the use of ISOCS calibration within our waste assay software.

Structures and Components

Mirion has over twenty years of experience characterizing contamination of nuclear components using ISOCS software. Waste or in-process components such as pipes, tubes, scrap, ventilation systems, and small irregular objects can be characterized using this approach to evaluate the activity of these components for continued waste storage or disposal, without the need for radionuclide calibration sources. ISOCS software can be deployed along with the iPIX Gamma Imager to locate a hot spot in real time.

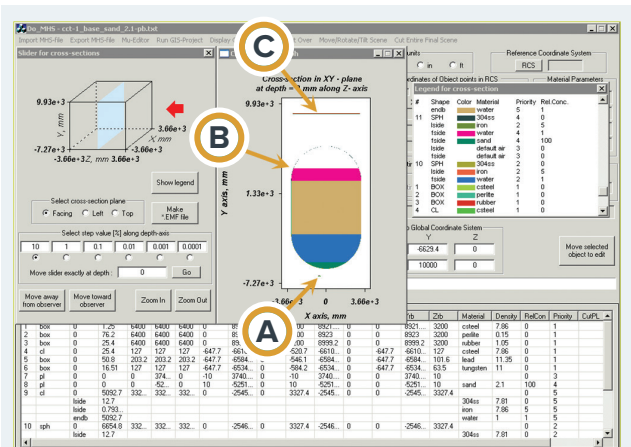

- Feature A is the detector location in the basement
- Feature B is the tank water level
- Feature C is the detector location on the roof

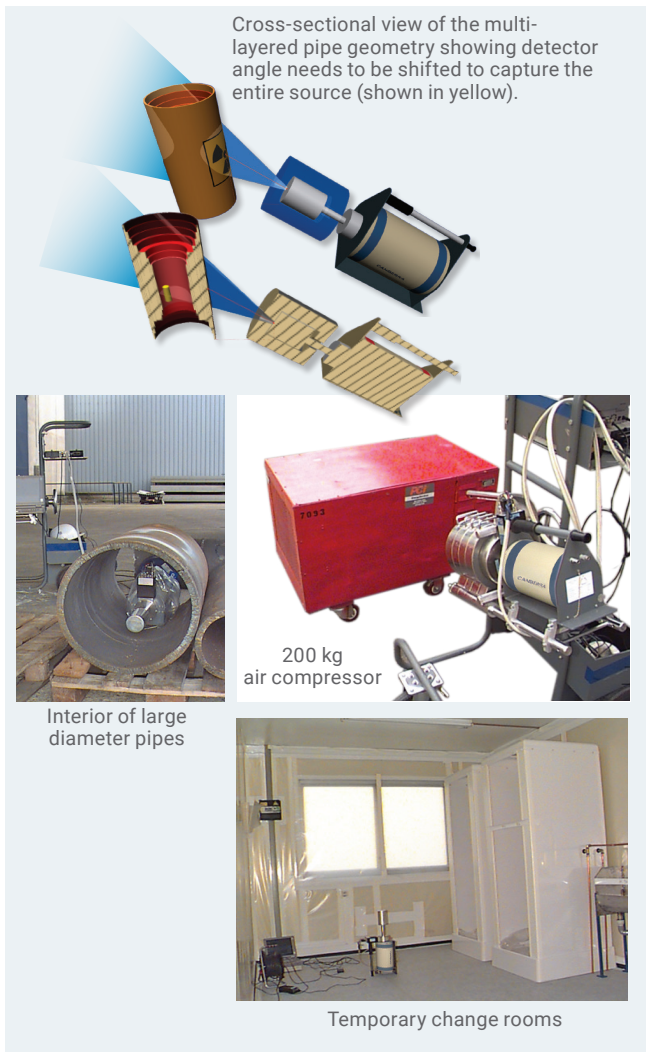
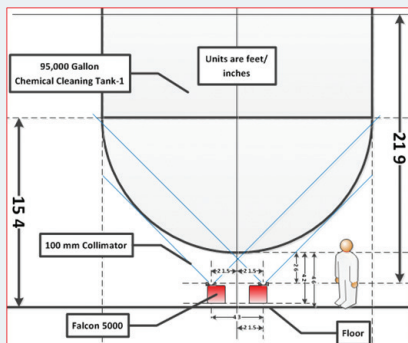

Monte Carlo modeling for studies or calibrations

We support mathematical modeling using MCNP for a range of potential applications. This could include performance prediction and calibrations for detection systems, radiation safety analysis and design, and optimization of spent fuel management.

Underwater Measurements

To obtain accurate quantitative results, our sealed, electrically cooled HPGe detector can be used in ponds and rivers.

The SMOPY system is used for underwater spent-fuel burn-up measurements in fuel pools. SMOPY system can also be used to characterize fuel rods. Our detectors can be mounted in a Remotely Operated Vehicle (ROV) to survey large underwater areas.

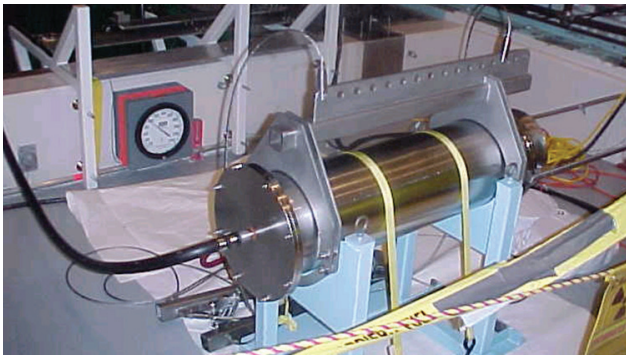

Radiation Tolerant Cameras

CCTV monitoring of nuclear generating, reprocessing, waste management and research facilities is of vital importance during the decommissioning and dismantling phases.

Mirion radiation tolerant inspection and surveillance systems, whether permanently located within the plant or used in portable or temporary configuration are designed to survive the hostile environments frequently encountered.



Nuclear Holdup Measurements

Measurement of radionuclide material inventory or holdup in plant systems, tanks or piping

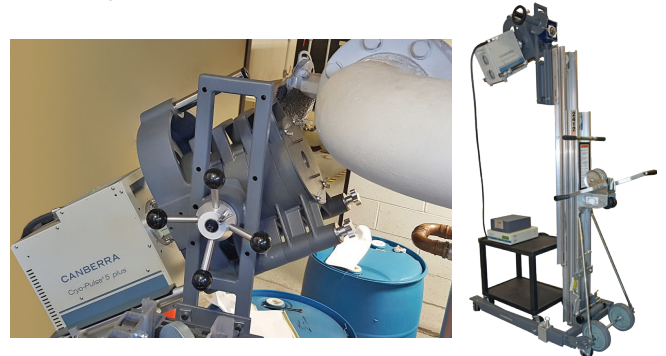

“Holdup Measurements” refers to the measurement of accumulations of nuclear material, most often uranium, in processing equipment such as pipes, tanks, pumps, calciners, filters, etc. They are integral measurements at uranium enrichment and fuel processing facilities. The main drivers for these measurements are Criticality Safety and Nuclear Material Accountability.

Mirion offers an alternative to the Generalized Geometry Holdup (GGH) approach using the ISOCS software to model a wide range of different source/detector geometries. Given that holdup campaigns are usually restricted to a small set of measurement geometries, site-specific and project-specific sets of ISOCS models could be developed for different customers. In addition to combining ISOCS software with the traditional NaI-based measurements, several viable alternatives, including CeBr detectors, HPGe detectors, CZT detectors, and the CdTe-based iPIX gamma camera can also be used.

Waste Characterization

Item sentencing (drum, container or item assays)



Mirion has significant experience and expertise in non-destructive assays for waste measurement. Gamma assay, neutron assay, and combined gamma/neutron systems are available to measure containers ranging from non-packaged waste to vehicles. We offer a full range of measurement solutions to meet your site waste characterization needs.

The Measurement and Expertise Team can be deployed on site to provide a customized solution to fit your specific project.



Protect What's Next™



MIRION
TECHNOLOGIES

Copyright © 2023 Mirion Technologies, Inc. or its affiliates. All rights reserved. Mirion, the Mirion logo, and other trade names of Mirion products listed herein are registered trademarks or trademarks of Mirion Technologies, Inc. or its affiliates in the United States and other countries. Third party trademarks mentioned are the property of their respective owners.